

# The LETTER LOK 3000 Return Fastener

Designed to fasten the open ends of channel letter returns up to a combined thickness of 0.125" in aluminum.

The LETTER LOK 3000 Return Fastener is an air over oil powered clinching machine featuring a one-piece steel frame with a 3 1/4" or 4 1/2" throat.

This time saving machine eliminates drilling and pop riveting open letter returns and letter centers. Installed with Norlok Technology's special tooling\* this versatile fastening machine can produce a UL recognized fastener in two pieces of aluminum.

The LL3000 is nearly maintenance free and is supplied with a tooling set for 0.040" aluminum and comes complete with a spring balancer for mounting to our optional mobile cart or a customer supplied fixture. Unpacking and attaching a 3/8" air line is all that is required for set-up.

The LL3000 is a portable machine and can be used for fastening applications in any area where you have access to a 3/8" air line and 75 pounds of air pressure.

\*Norlok Technology part # MP70001 and MP70002

## LL3000 Mobile Cart

This cart is perfectly balanced to carry the LETTER LOK 3000 Return Fastener

The optional Mobile Cart for the LETTER LOK 3000 Return Fastener is an all-steel welded cart designed to support the portable tool for easy locating and transportation in any environment.

The cart comes complete with 3" diameter locking casters, collapsible design for easy shipping and storage, mounting for power unit and hooks for machine and hydraulic hoses.



26 Adams Blvd, Brantford  
ON, Canada N3S 7V2  
ph 519.759.5896 fx 519.759.2948  
info@norlok.com www.norlok.com

**SPECIFICATIONS – LL3000 Return Fastener  
(Model – LL3000 MDWA)**

- Press Design:** Single steel "C" frame.
- Features:** Air over oil intensifier.  
**Single shot auto return.**
- Stroke:** 1/4"
- Throat:** 3 1/4" or 4 1/2"
- Work Height:** Not applicable
- Upper Tooling:** Fast change punch.  
Replaceable punch stripper.
- Lower Tooling:** MDWA insert style.  
Adjustable to suit material thickness.
- Capacity:** **MEDIUM DUTY (0.18"Ø PUNCH)**  
Aluminum:  
MAX: Combined thickness of 0.125"  
MIN: Two ply 0.024"
- Cycle speed:** 30 - 40 CPM (standard speed).
- Air Requirements:** 65 psi (min) 85 psi (max)  
75 psi (recommended)  
Approx. 0.8 cu ft free air per cycle.  
(5 HP @ 40 clinches per minute)
- Dimensions:** Width 2-1/4" (overall)  
Length 12 1/8" (overall)  
Height 8 1/4" (overall)  
Weight 15 lbs Workhead  
45 lbs Booster
- Options:** 7 ft tall mobile cart with 2 1/2 ft arm.

**Typical Joint Strengths (Aluminum)**

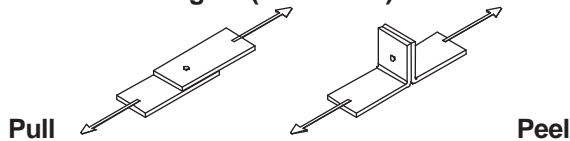

Material Thickness Punch side/ Die side	Pull (lbs)	Peel (lbs)
0.090" to 0.063"	240	95
0.080" to 0.080"	265	90
0.063" to 0.063"	240	72
0.063" to 0.040"	270	50
0.040" to 0.040"	175	60

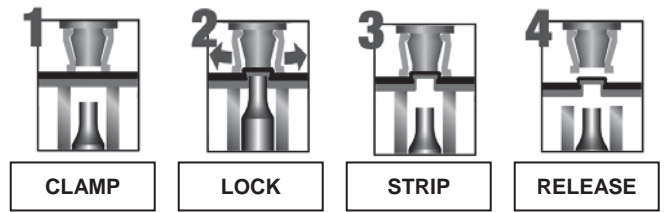

**LL3000 RF**

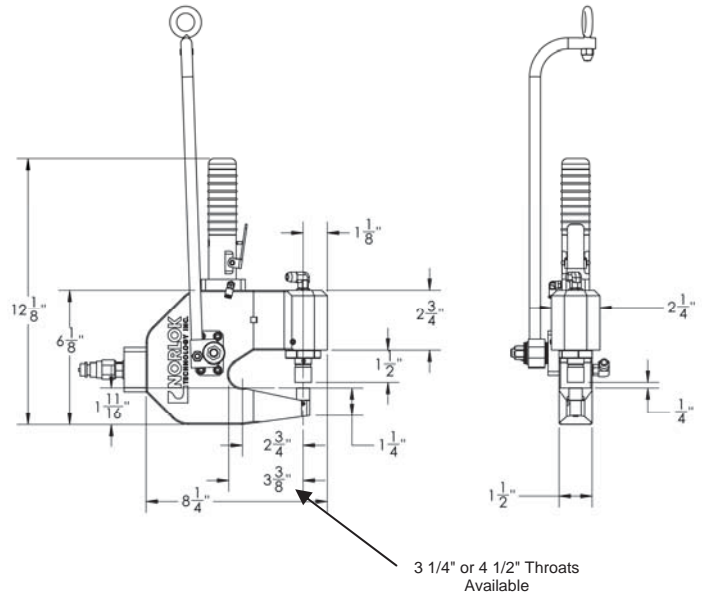

**Mobile Cart**

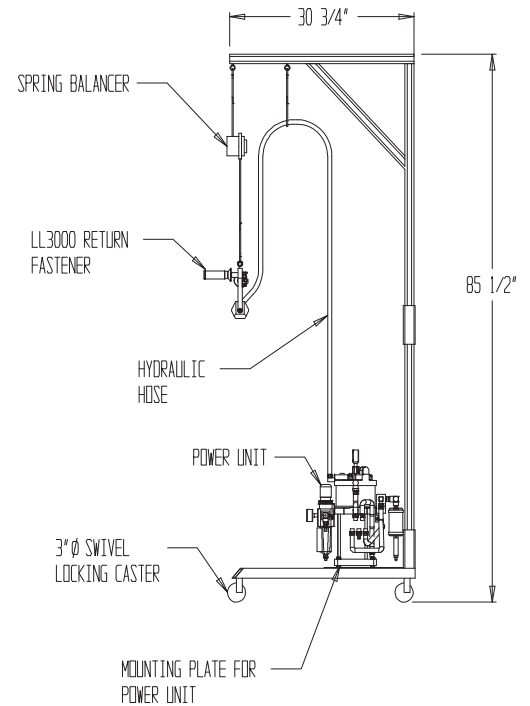

26 Adams Blvd, Brantford  
ON, Canada, N3S 7V2  
ph 519.759.5896 fx 519.759.2948  
info@norlok.com www.norlok.com