

Engel Industries, Inc.

Shopmaster Index

1. Shopmaster Applications – p.1
 - A. The Motorized End Cutter and the Motorized Length Cutter – p.2
 - B. Cutting Metal with the End Motorized Cutter – p.3
 - C. Cutting Metal with the Length Motorized Cutter – p.3-4
 - D. Angular Cutting – p.5-6
 - E. Slitting of Metal – p.7
 - F. Multiple Notching – p.7-9
 - G. Metal Storage – p.9
 - H. “Lay-Out” Operations – p.9-11
 - I. Summary – p.11
2. Items Included In Shipment – p.12-13
3. Setting Up Instructions – p.13-15
 - A. Use of the Two Guide Bars – p.15
 - B. Lubrication – p.15
 - C. Adjustments – p.15
 - D. Applications – p.16
4. Instructions – p.17
 - A. Adjustment of Cutter Wheels – p.17
 - B. Adjustment of Motorized Cutters on Cutter Tracks – p.17-19
 - C. Adjustment Instructions for Shopmaster Cutters – p.20
5. Shopmaster Cutter Diagram – p.21

6. Shopmaster Lubrication Instructions – p.22
 - A. Lubrication Prior to Starting – p.22
 - B. Lubrication During Operation – p.22
7. Calibrated Steel Bars Diagram – p.23
8. Cutter Wheel Alignment Diagram – p.24
9. Shopmaster Cutter Assembly Diagram – p.25
10. Shopmaster Parts List – p.26
11. MAGNO-PAK Parts List – p.27
12. Warning – p.28
13. Shopmaster Wiring Diagram – p.29

Applications

The utility value in a tool depends on the simplicity, use, and improvement in methods made possible in the applications of the tool. The SHOPMASTER provides an arrangement of specially designed and revolutionary tool components on one complete assembly for employing the quickest and best methods known in performing the sheet metal shop operations which are necessary in preparing metal for forming and assembling.

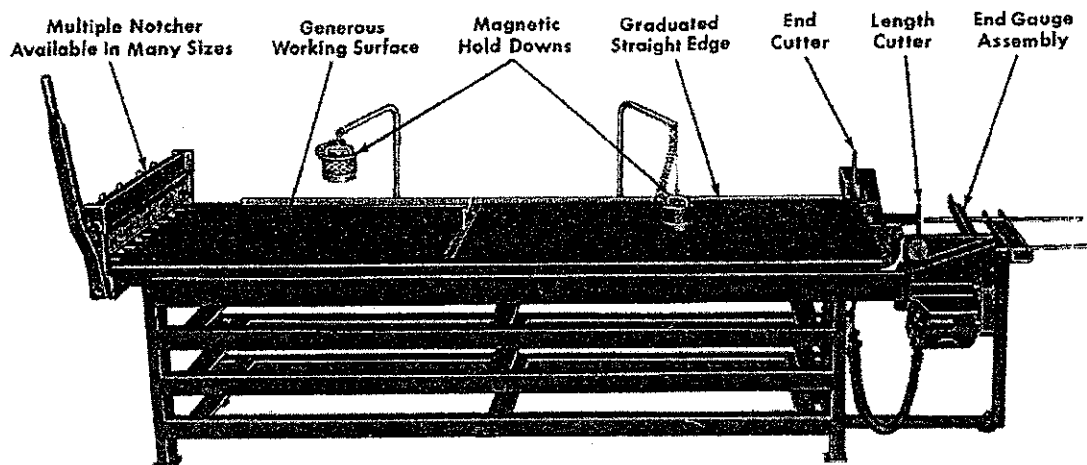

Storage Racks Are Optional On All Models

The applications of the SHOPMASTER are, therefore, based on the following features:

It is designed to efficiently handle the time consuming operations in sheet metal shops which require specialized training and knowledge. These operations, in many instances, are the ones that account for much confusion in shops. Many users have perfected their techniques and methods in applying this tool and have turned many specialized operations into mechanical operations.

The exclusive Engel individual tool components are designed, constructed, and arranged on the SHOPMASTER so that many operations can be combined and accomplished in a direct and simple manner with little effort, but with speed, precision, and ease.

Calibrated surfaces in relation to the cutting line of travel of the motorized cutters reduce metal cutting operations to sight methods.

The calibrated bar surface in relation to the multiple notcher units reduces metal notching operations to sight methods.

Measuring, laying out, punch marking, and hand cutting of metal is eliminated. If, however, laying out of metal is required for unusual

operations, the graduated straight edge bar mounted lengthwise along the back side of the table and the special 24" x 36" calibrated square provide an ingenious drafting table arrangement for laying out fittings and patterns. The fast sight and scribe method without measuring made possible by these components can be mastered very easily even by an average layman who has not had experience in "lay-out" work.

The SHOPMASTER with its tool components introduces revolutionary sheet metal shop methods and reduces handling and transportation of metal to a minimum. It also greatly reduces shop space requirements to a minimum.

The SHOPMASTER is designed for versatility in producing the diversified pieces of metal required in sheet metal shop operations. The components are operated with little or no setting up effort. A high quality and great quantity of output can, therefore, be realized from this tool.

The Motorized End Cutter and the Motorized Length Cutter

The ingenious design and mounting of these two motorized cutters provide two different types of applications, namely, one for cutting and one for slitting operations. Each of the smooth flat type cutting wheels on these units are power driven to cut or slit metal without distortion or burring. These units are mounted on their respective cutter rails to automatically travel through metal in cutting operations if the metal is held on the tabletop. If, however, the motorized cutter is secured at a point along the cutter rails with a "C" clamp, metal moved into the converging point of the cutting wheels is automatically pulled through the wheels in slitting operations. In neutral position, on the starting end of the rails, the cutters are in a non-operating position. As soon as the cutters are moved out of neutral position, however, they start operating for cutting or slitting metal. The throat less design of these motorized cutters, when used as cutting tools or as slitting tools, makes it possible to cut or slit metal to any width or to any length.

Straight cutting of metal is dependent on the straightness of two constants or the straightness of the two cutter rails. These rails are attached to the table unit with threaded studs so that they can easily be adjusted to assure straight cutting.

In operation these motorized cutters are self-aligning within the limits set by the two directional adjusting bolts on each of the motorized cutters. The adjustment of these bolts is seldom required but is very simple to make. (See Setting Up and Operating Instructions.)

The tolerance between the two cutting wheels, where these wheels lap, is set at the factory for cutting light gauge metal as well as heavy gauge metal within the capacity range of the cutters. The $\frac{3}{4}$ horsepower cutters have a limited cutting capacity of 18 gauge galvanized iron. No adjustment in cutters is required in changing from one gauge to another gauge within the capacity limitations of the cutters.

Cutting Metal with the End Motorized Cutter

Place metal on the tabletop so that the front edge is adjacent to the calibrated straight edge. Locate the left edge of the sheet at the calibrated point identifying the desired length. Move the end cutter out of neutral position so that the cutting wheels are brought into contact with the metal for automatic cutting and cutter movement through the metal. (See figure 1)

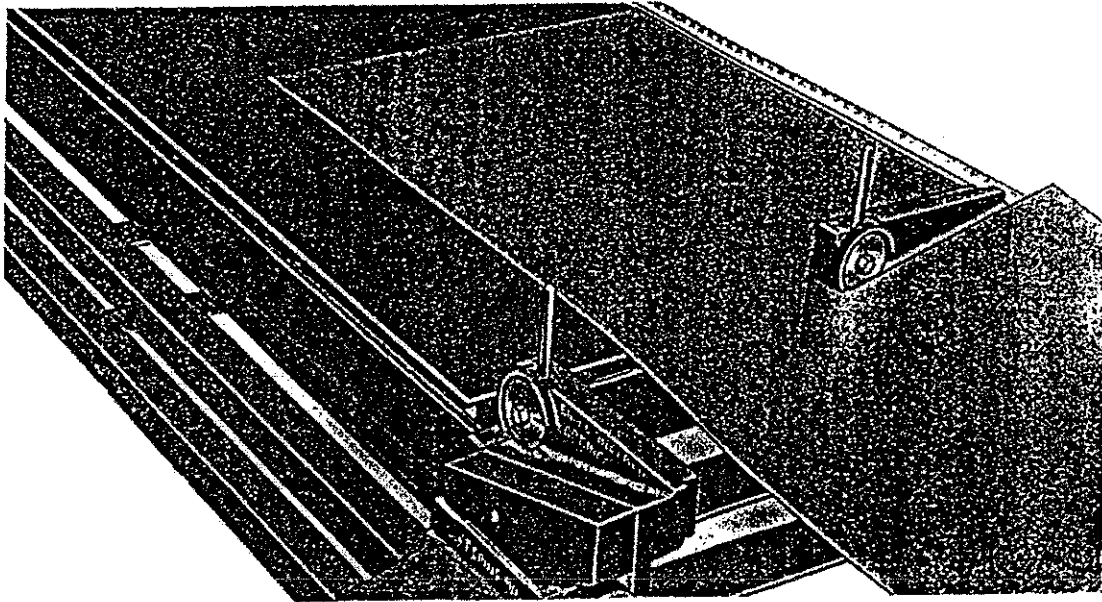

Figure 1

Cutting Metal with the Length Motorized Cutter

Position metal on the tabletop so that the line to be cut is directly over the cutting line of travel of the cutting wheels of the length cutter. Place the two Magno-Pak units on top of the metal and flip the off-on switch on each of these units to hold the metal in place on the tabletop. Move the length cutter out of neutral position so that the cutting wheels are brought into contact with the metal for automatic cutting and cutter movement through the metal. (See Figure 2)

Corresponding notched cuts on each end of a sheet of metal or corresponding punch marks on each end of a sheet metal serve to establish the line to be cut for positioning metal over the cutting line of travel of the cutting wheels. If notched cuts or punch marks are not used, measurements from the length edge of a sheet of metal to the cutting line of travel of the cutting wheels can be used to establish the line to be cut in positioning metal over the cutting line of travel of the cutting wheels.

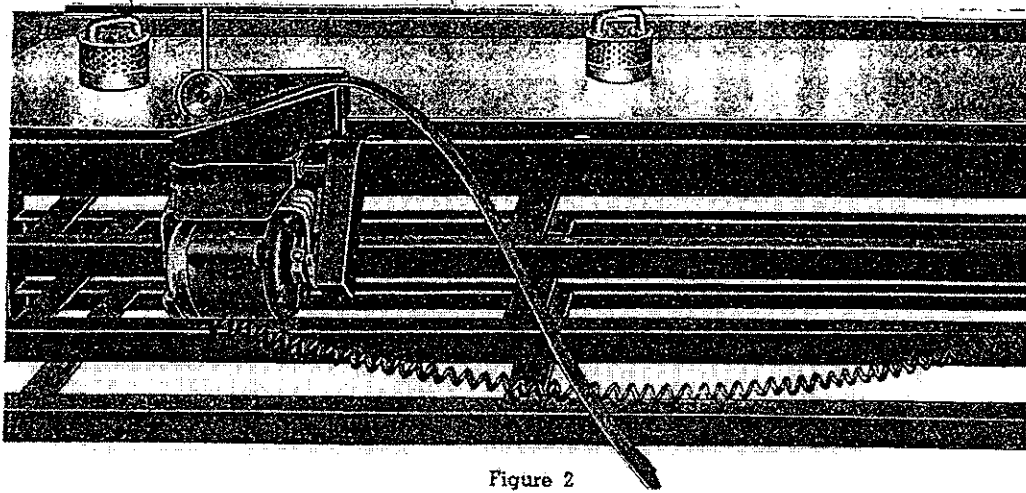

Figure 2

Where many strips of metal are to be cut to the same width dimension, use the length cutter gauge assembly. The calibrated bar on the gauge assembly mounted on the left end of the table top is used to sight the distance to be established between the cutting line of travel of the cutting wheels of the length cutter and the gauge point for the width dimension of the strips to be cut. The corresponding gauge point on the motorized cutter assembly is set by moving the length cutter to the calibrated gauge assembly and by locking this gauge point in position to match the gauge point on the calibrated gauge assembly. This provides two gauge points of equal distance from the cutting line of travel of the cutting wheels of the length cutter and the butting points for metal to be cut to the same dimensions. The gauge point on the cutter assembly drops out of position after it has served its purpose in positioning metal along the cutting line of travel of the length cutter (See Figure 3)

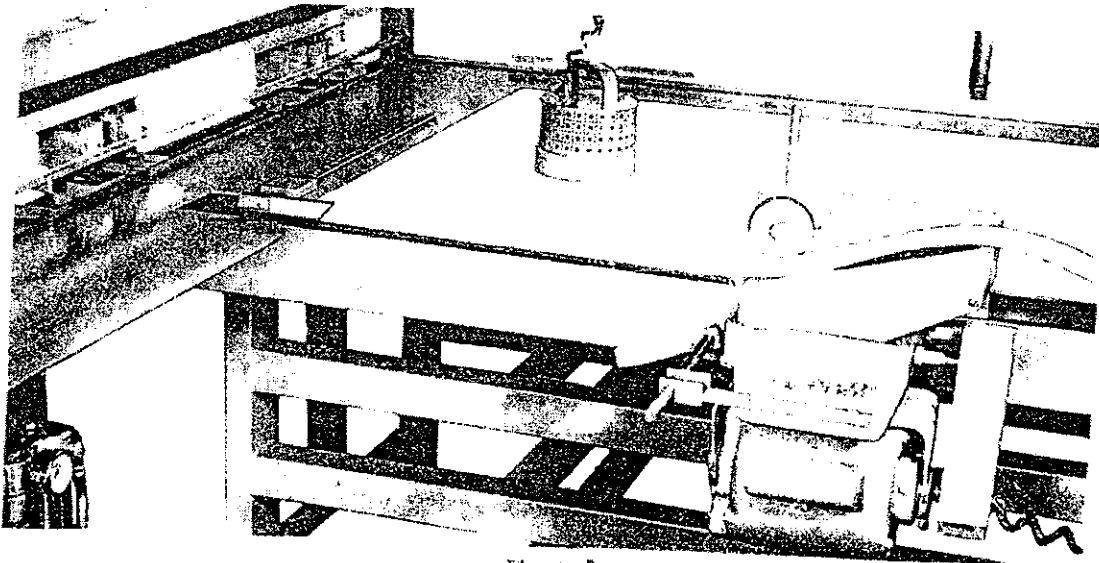

Figure 3

Angular Cutting

Angular cutting of metal can, of course, be accomplished on this tool by positioning metal on the table top so that the angular line to be cut is directly over the cutting line of travel of the cutting wheels. (See Figure 4)

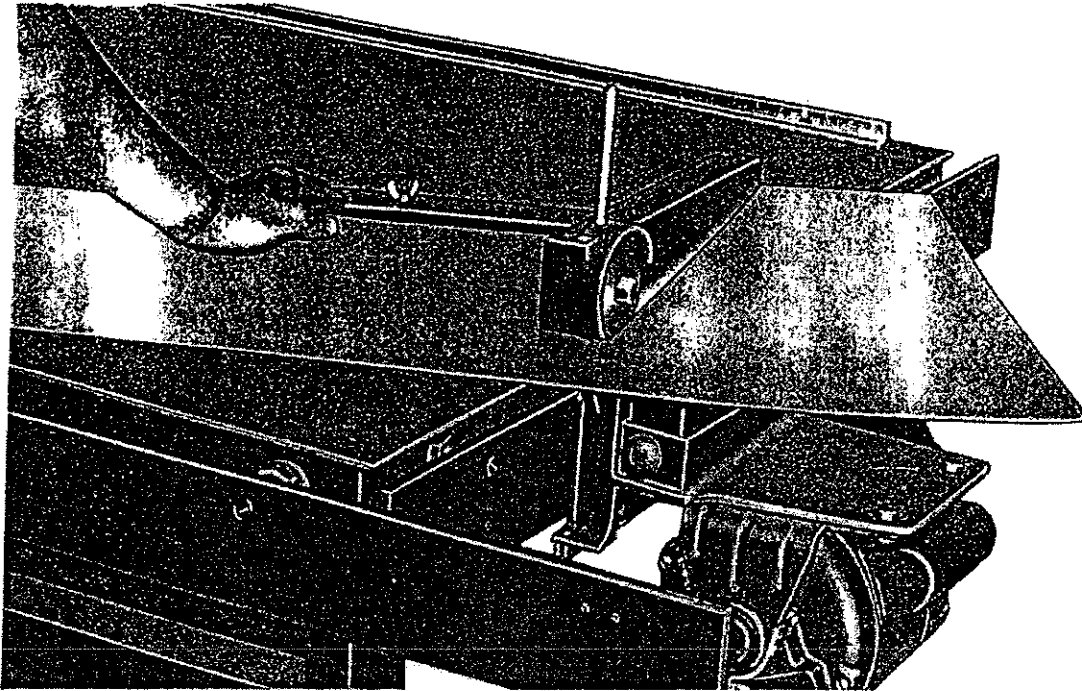

Figure 4

Where many angular pieces of the same design are to be cut, use the guide bar for angular cutting furnished with the tool and the end gauge assembly, which is standard on this tool.

To make 10" to 4" transition pieces 10" deep, cut or slit a strip of metal 10" wide as explained in preceding paragraphs. Lay out the 10" to 4" by 10" deep transition on the right end of the 10" strip so that the 10" base line of the transition is along the top edge of the strip. Direct the guide bar for angular cutting so that when the top edge of the strip is adjacent to bottom side of the guide bar, the angular line along the right side of the transition piece to be cut is directly over the cutting line of travel of the end cutter cutting wheels. Tighten the thumbnut on the guide bar and use the end cutter to cut along this angular line. (See Figure 5)

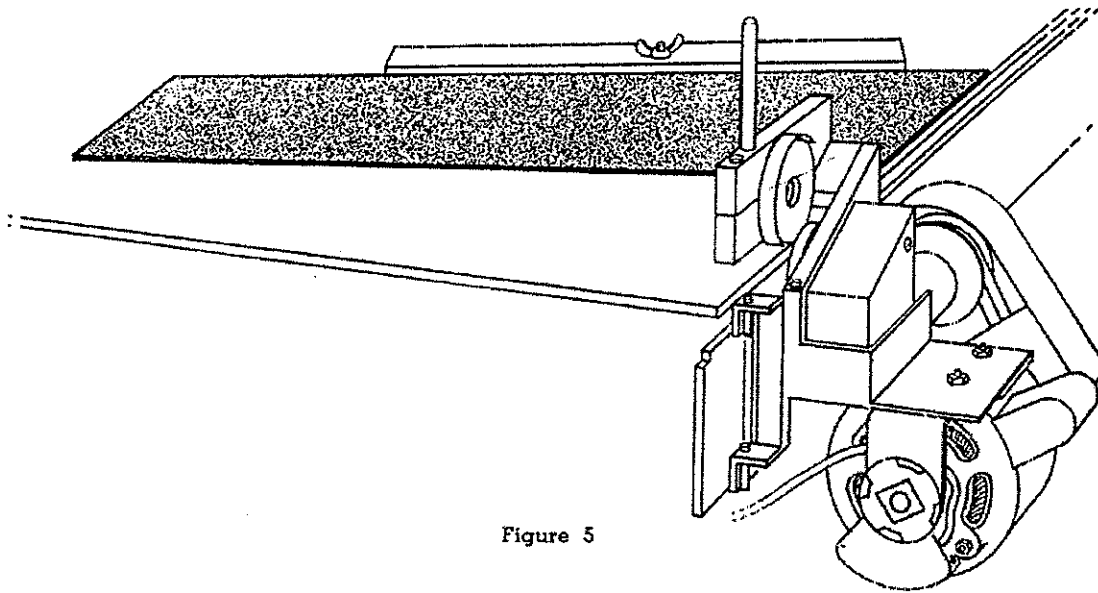

Figure 5

Flip the strip over so that the base line of the transition is towards the front side of the tabletop. Establish the 10" base dimension of the transition piece by sliding the strip along the bottom side of the guide bar towards the end gauge bar until the distance between a point on the gauge bar and the left cutting point of the base of the transition is 10" as measured on a line parallel along the bottom edge of the strip. (See Figure 6). (This gauge bar can be adjusted to any fraction of an inch in relation to the cutting line of travel of the cutting wheels of the cutter.) Use the end cutter to cut the left angular side of the transition piece. Additional pieces of the same size and shape can be cut to size by merely flipping the strip over, sliding the strip to bring the extreme point on the bottom edge against the gauge bar, or cutting the left side of the transition piece.

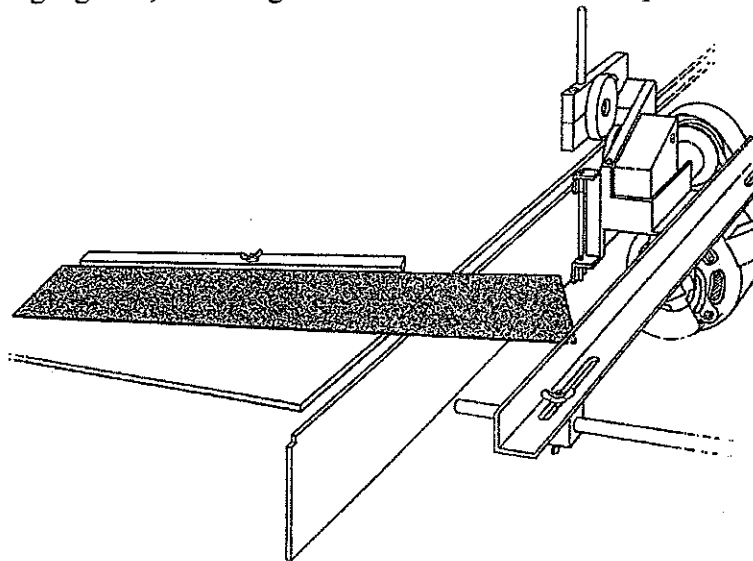

Figure 6

Slitting of Metal

Either motorized cutter can be locked into position along its respective cutter rail with a "C" clamp. Metal moved into the converging point of the cutting wheels is automatically pulled through the wheel in slitting operations. (See Figure 7). A galvanized iron jib, 4 or 5 feet long with a standing bead is most commonly used where many pieces of metal having the same width dimension are to be slit. The jig can be secured instantly on the tabletop with the Magno-Pak units. The standing bead serves as a guide edge for directing metal along a straight line into the cutting wheels.

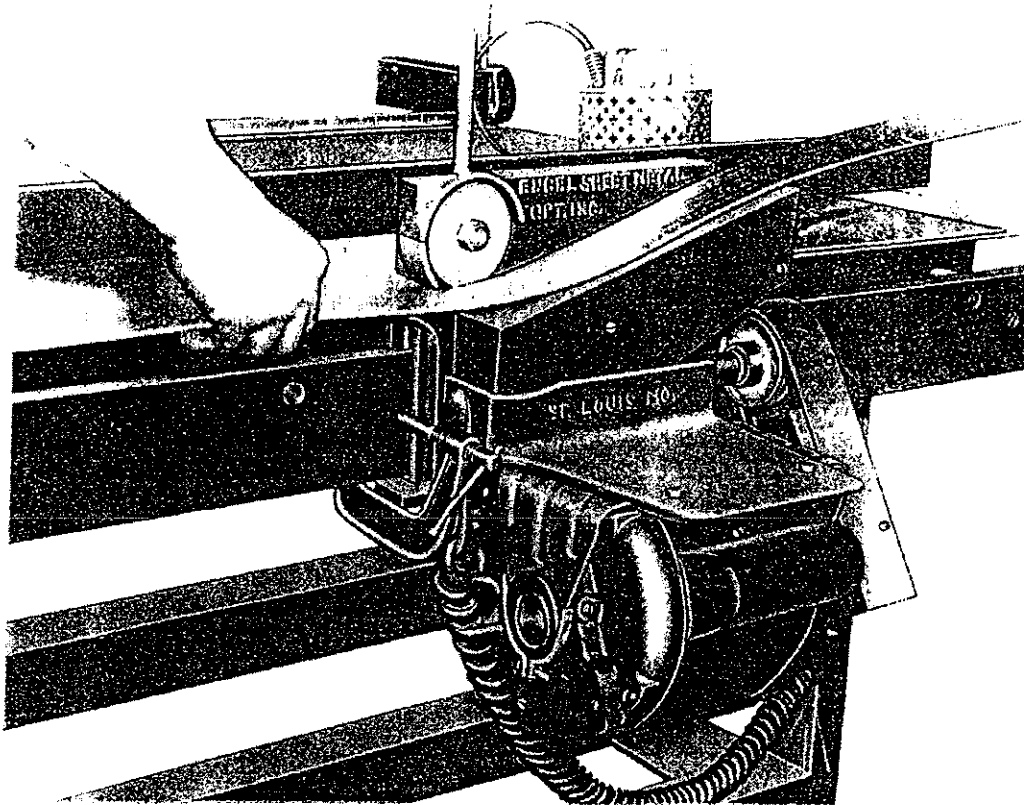

Figure 7

Multiple Notching Operation

The Engel multiple notching unit is designed and arranged on the SHOPMASTER to greatly expand sheet metal methods and applications on this tool. The methods made possible in this design and arrangement include multiple notching of metal almost instantly without measuring, marking, or hand cutting of notches. Of utmost importance, are the methods made possible in combining and reducing many shop operations to a few. In the multiple notching operations, flange points, forming points, and cutoff points can be established as explained above. The arrangement of the multiple notching unit on

the SHOPMASTER, however, makes it possible to use corresponding cutoff points and to merely shift the metal over the tabletop in positioning the cutoff points over the cutting line of one of the motorized cutters for cutting operations. This eliminates "laying-out" operations. A typical example of using corresponding notched cuts in placing metal over the cutting line of cutters for cutting operations is shown in Figure 8.

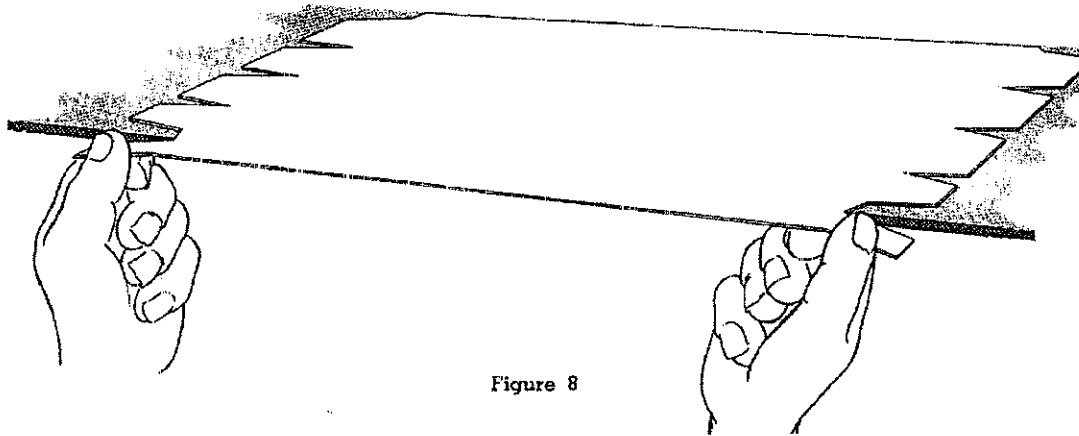

Figure 8

The design features in the Engel multiple notching units greatly facilitate setting the notcher units on rails for notching operations. The quick setting type of notcher units can conveniently and instantly be set, locked in position, or removed from the notching rails from the front or operating side of the notching unit. (See Figure 9)

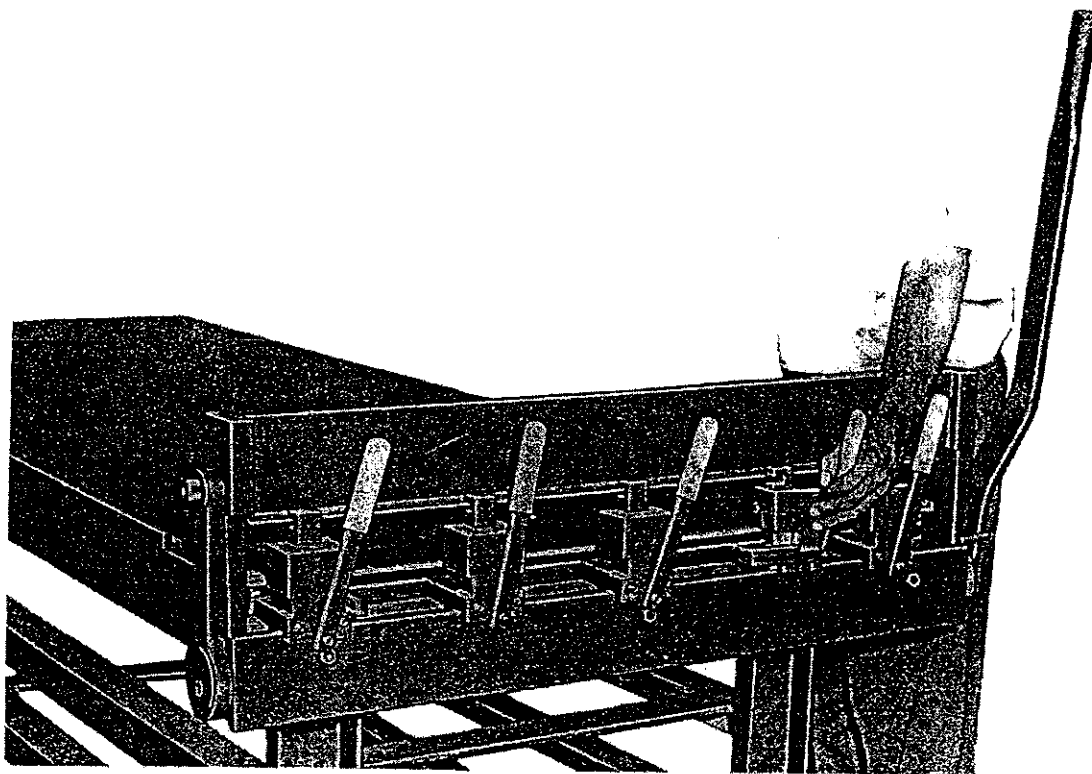

Figure 9

The notcher units can also be conveniently and instantly spaced to a calibrated bar for required patterns from the front or operating side of the notching unit (See Figure 10)

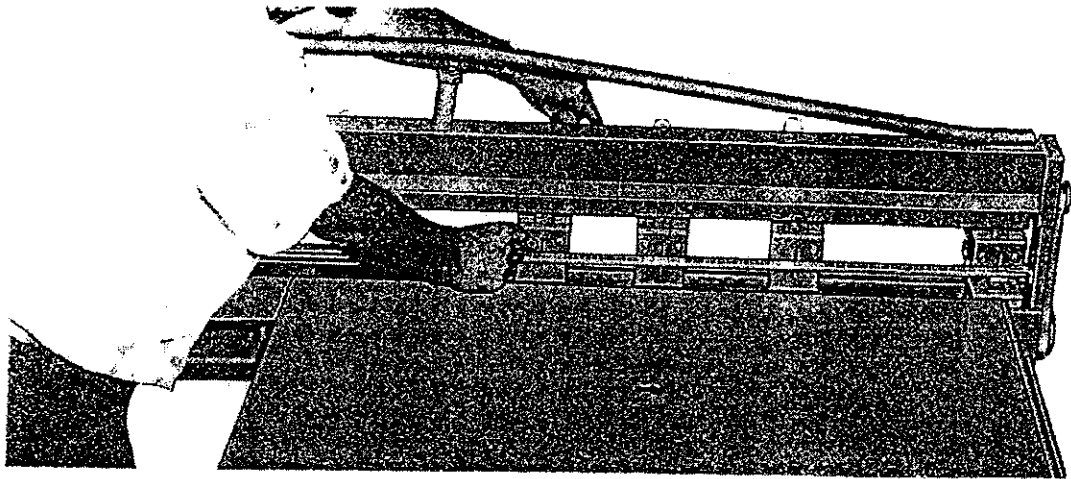

Figure 10

Although notcher units with standard "LOCK" type and "V" type dies, generally used for duct work, are furnished as standard with notching assemblies, notcher units with special dies can be furnished for special notching to expand the applications of multiple notching assemblies

Metal Storage

Metal storage racks are optional on all standard SHOPMASTER Models. The storage racks make it possible to store metal in sizes and gauges most commonly used, within easy reach of the operator. Proximity of metal within easy reach of the layout man saves time and many steps. An orderly arrangement of sheets in the storage rack of a SHOPMASTER will help keep working areas clean. It will also keep sheets protected and sorted. Shop space is conserved in combining metal storage space and a work bench in one tool.

"Lay-Out" Operations

"Lay-out" operations, including pattern or diagram drawings of fitting or designs on metal when required, can be very accurately and quickly performed on the SHOPMASTER by a "SIGHT AND SCRIBE METHOD" made possible because of the components on this tool. The precision calibrated straight edge of a sheet of metal, which is placed adjacent to the straight edge. The special 24" by 36" square, furnished with the SHOPMASTER, provides a 36" long calibrated surface for measuring points perpendicular to the calibrated straight edge. By using these two components, any point or scribe line can be sighted within the range of the 100" long bar, and the 36" long calibrated surface for the measuring points perpendicular to the calibrated straight edge. By using these two components, any point or scribe line can be sighted within the range of the 100" long bar, and the 36" long calibrated surface of the square. To illustrate the

use of these two components see Figure 11 showing the square adjacent to the calibrated straight edge.

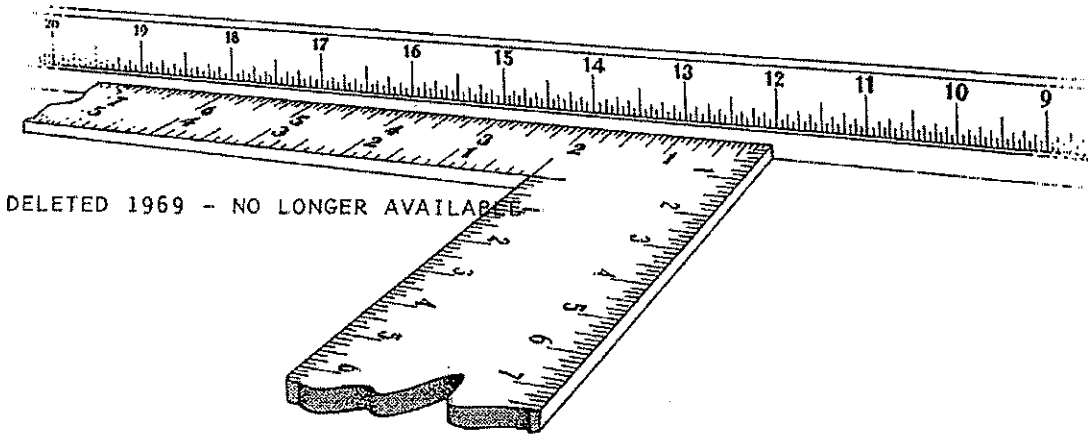

Figure 11

You can readily see how advantageous the calibrated surfaces on the straight edge bar and the square are in locating points and dimensions within the range of these calibrated surfaces. Just as the draftsman on a drawing board uses the straight edge and triangle in developing his drawing or "lay-out," you can use the straight edge bar and square in developing or "laying-out" fittings and patterns on metal. The calibrated surfaces, however, add many important advantages not enjoyed on the drafting board. The calibrated square can be used in conjunction with the calibrated straight edge bar as a slide rule in adding or subtracting measurements, and in locating points for scribe lines, trammel points, or divider points by sight. It can, also, be used to locate any point within 36" perpendicular to the straight edge bar by sight.

On Figure 11 assume that you use 12" on the bench bar as the centerline of a fitting.

To add $2 \frac{1}{16}$ " to the left of this centerline:

Slide your square along the bench bar so that the outside edge of the square is perpendicular to the bench bar at 12".

Sight $2 \frac{1}{16}$ " on the calibrated edge of the square parallel to the bench bar.

The corresponding calibration on the bench bar over $2 \frac{1}{16}$ " on the square is $14 \frac{1}{16}$ ". This is the locating point for $2 \frac{1}{16}$ " to the left of the 12" centerline. You can slide your square to this point for scribing, or you can use this point for a trammel point, or a divider point

To subtract $2 \frac{1}{16}$ " to the right of the centerline of 12":

Sight $2 \frac{1}{16}$ " on the calibrated edge of the square parallel to the bench bar and slide your square along the bench bar so that the $2 \frac{1}{16}$ " point on the

square is directly under 12" on the bench bar. The corresponding calibration on the bench bar at the edge of the square is $9 \frac{15}{16}$ ". This is the location point for $2 \frac{1}{16}$ " to the right of the 12" centerline. You can use this point for a scribe line, or you can use this point for a trammel point, or a divider point.

Just as you can locate by sight points or dimensions parallel to the bench bar you can, also, locate by sight points or dimensions perpendicular to the bench bar for length of scribe lines, or for trammel points or divider points.

Summary

The information set out in the preceding pages explains the basic applications and methods that can be accomplished on the SHOPMASTER. Customers, in using this tool, have perfected many additional applications and methods not explained in this bulletin.



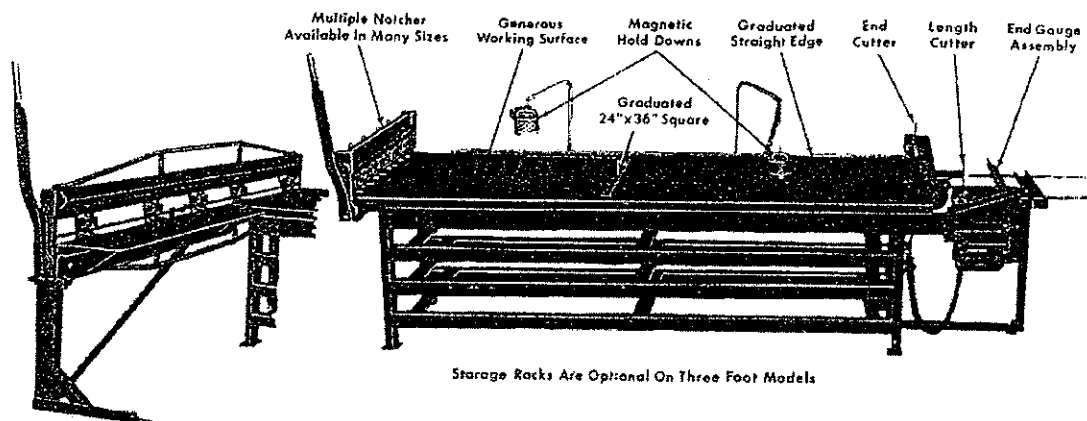

Items Included in Shipment:

1 – SHOPMASTER table. (On units having a notching assembly of the same length as the width of the table, the notching assembly is mounted on the table.)

1 – Notching assembly crated on SHOPMASTERS with notching assemblies, which extend beyond the width of the table.

1 – Wood box containing: one end motorized cutter; one length motorized cutter with length cutter swing stop, bracket, and rod assembly mounted; two magnetic hold downs (MAGNO-PAK units); two MAGNO-PAK support arms with nylon cords; two support arm brackets with attaching bolts, nuts, and washers; two MAGNO-PAK counter weights; one complete wiring harness including two micro switches and two make up boxes for the SHOPMASTER table assembly; one end gauge tee; three end gauge round bars; one end gauge stop (angle iron); two guide blocks with thumb screws; one calibrated swing stop assembly for length cutting. (The swing stop guide is mounted on the SHOPMASTER table); two accessory guide bars with attaching bolts and thumbnuts; one 24" x 36" calibrated square; two cans of lubricant for cutters; and five standard notcher units. (On six, eight, and ten foot notching assemblies, the notcher units are shipped mounted on the bedplates of the notching assembly)

Note 1: On SHOPMASTERS with air powered notching assemblies, this wood crate, also, contains one air cylinder assembly including the mounting bracket and attaching bolts and nuts; one oiler-filter-regulator assembly; one foot pedal control; and one hose assembly.

Note 2: On SHOPMASTERS with motor powered assemblies, the notching assembly is shipped in one crate complete with motor, controls, power transmission, and wiring harness mounted.

SETTING UP INSTRUCTIONS

Set the table unit on the floor and **BE SURE TO LEVEL.**

Mount the motorized cutter marked "END CUTTER" on the right end cutter rail after removing the stop bolt and nut from this rail. (The two top vertical track bearings ride the top of the cutter tail and the two lower vertical bearing rails straddle the bottom of the rail.) Mount the motorized cutter marked "LENGTH CUTTER" on the front cutter rail in the same manner. Reinstall the stop bolts and nuts in each cutter rail

Attach the two MAGNO-PAK support arm brackets, with the 1/4" bolts, washers, and nuts furnished on the back plate of the table assembly. (The 1/4" boles are drilled in this plate for these brackets.) Slip units over the tabletop from the nylon cords. Suspend the counterweight units on the opposite ends of the nylon cords.

Install the two make up boxes and the assembled wiring harness on the table unit (all holes are drilled) in accordance with the following sketch:

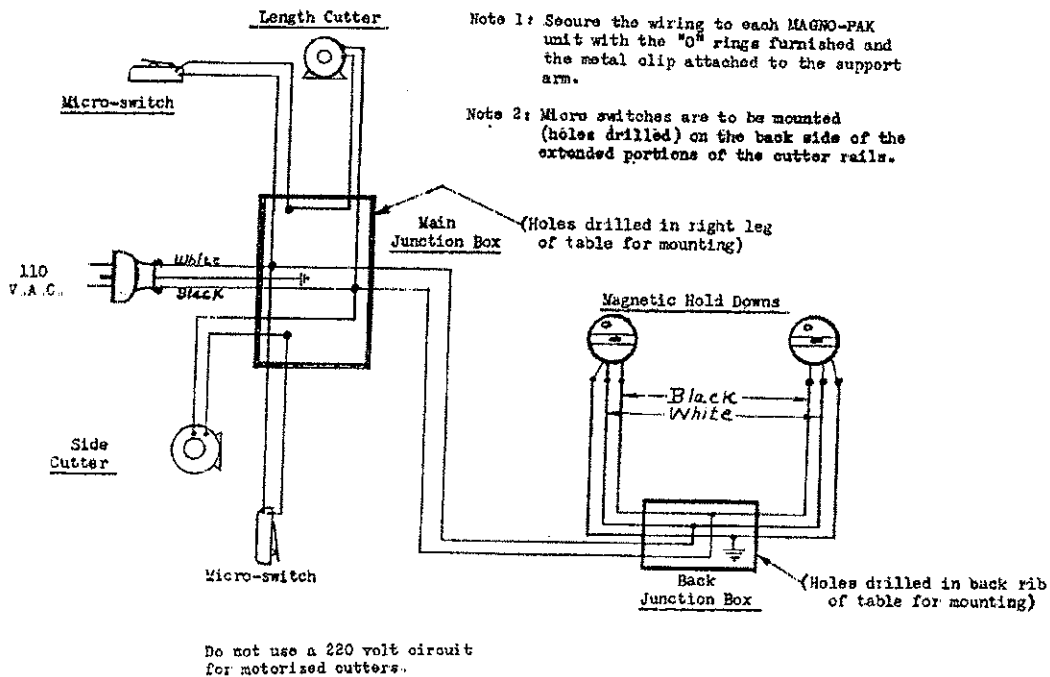

Insert the threaded end of the end gauge tee (1 ½" pipe assembly) in the 1 ½" standard tee welded on the end gauge cross support between the two right end legs and tighten this end gauge tee. Insert each of the two end gauge round bars in the holes provided in the end gauge tee. Slide the guide blocks with thumbscrews on the round bars. Attach the end gauge stop (angle iron) on the topside of the guide blocks. Insert the third round bar (brace) in the hole provided in the tee assembly, adjust assembly to the correct height, and lock the brace bar in position with the bolt furnished.

On SHOPMASTERS having a notching assembly of the same length as the width of the table, the notching assembly is shipped mounted on the table. On SHOPMASTERS with notching assemblies that extend beyond the width of the table, the notching assembly is shipped in a separate crate and must be attached to the left side of the table. Three 17/32" holes are drilled in the table bedplate to receive these bolts. (17/32" holes are drilled in the bed plate instead of ½" holes to permit raising or lowering of the notching assembly so that the top of the die plates on the notcher units, after these are set on the assembly bed plates, can be leveled with the top of the SHOPMASTER table surface). Attach the notching assembly to the table unit with the bolts, washers, and nuts furnished and level the notching unit on a surface parallel with the table unit. (Shim under the legs of the notching assembly if necessary). Attach the notching assembly apron to the SHOPMASTER table with the apron strap. You will find this strap on the bottom side of the apron. Loosen the bolt holding this strap, and remove the bolt and nut for attaching this strap on the SHOPMASTER table from the table. Line up the strap with the hole on the table, replace the bolt and nut for attaching the apron on the table and tighten. Also tighten the bolt for securing the strap on the apron. Install the five individual notcher units on the bed plates, with the beam assembly in the raised position, making sure that the horizontal grooves of the notcher unit pistons fit over the lift angle on the beam assembly, as shown in the following figure.

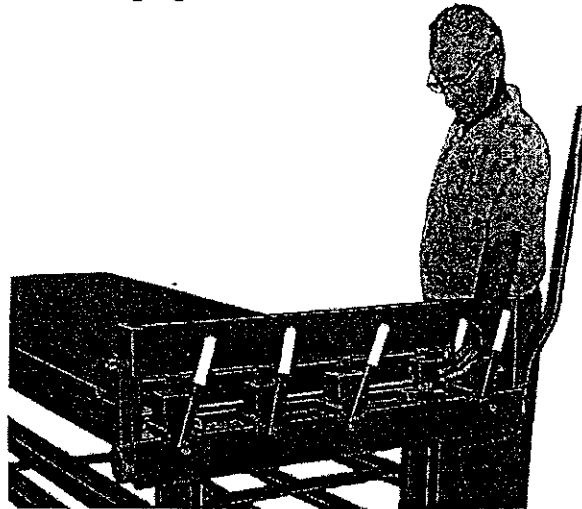

Note: Use finger tip pressure only on the handles of the notcher units in locking these units on the bedplates. The friction type lock arrangement for these handles can be easily adjusted if too much throw occurs in the handles.

Slide the calibrated swing stop assembly of the length cutter gauge into the swing stop guide block mounted on the table. The length cutter gauge swing stop is shipped assembled and mounted on the length cutter casting.

Use of the Two Guide Bars

(For cutting and notching many pieces of the same design)

One of the two accessory guide bars with bolt and thumbnuts is to be used to guide metal in a desired position in relation to the end cutter. The other guide bar with bolt and thumbnut is used to guide metal in relation to the notching assembly.

The bolt on these guide bars slips through the elongated holes cut in the tabletop. These guide bars are secured in a desired position by tightening the thumbnuts.

Lubrication

We must remove the grease from the lubricant wells of the cutters before shipment. **BEFORE USING THIS TOOL, IT IS THEREFORE IMPORTANT TO:**

Remove the front cover plate on each of the cutters. Fill the lubricant well of each of the cutters to a point approximately $\frac{1}{2}$ " above the bottom of the wells with the mechanic jelly lubrication furnished with the tool. Check and replenish this lubrication from time to time.

Also apply lightweight non-detergent motor oil in the cutter motors periodically.

Also apply grease in the alemite fittings on the notching assembly.

Use a number thirty or forty S.A.E. weight lubricating oil on the notcher unit pistons periodically.

Adjustments

The cutters ride their respective rails and not the edges of the steel tabletop. Accurate and straight cutting of metal is primarily dependent on the straightness and the level of the cutter rails. These rails are jig-set at our factory and **SHOULD NOT BE CHANGED IN THE FIELD**. If, however, a cutter rail has been bent in shipment, the rails are mounted on the bedplates of the table with threaded studs so that the rails can be leveled and straightened in the field. If this occurs, we ask you to notify our office so that one of our representatives can adjust the cutter rails for you.

Since the cutters ride the rails and not the edges of the steel table top, if the table top is buckled upward in shipment or in moving so that the metal is pinched between the table top and the body of the cutters, a large adjustable end wrench can be used to straighten the edges of the table top to avoid pinching the metal.

As explained above, accurate and straight cutting of metal is primarily dependent on the straightness and the level of the cutter rails. Minor adjustments are sometimes required on the 1/4" (spring loaded) adjusting bolt and the 1/4" adjusting bolt and nut (not spring loaded) which adjusting bolts are located at the topside of the cutter back plate. DO NOT ADJUST THESE UNNECESSARILY, AND BE SURE THAT THERE IS ONLY A SLIGHT TENSION ON THE SPRING OF THE SPRING LOADED BOLT. THIS MUST NOT BE TIGHT.

If you find that the metal is being pulled away from the table top or is being pushed toward the table top in cutting:

Loosen both 1/4" bolts by turning counter-clockwise.

Tighten the 1/4" bolt (not spring loaded) by turning clockwise ONLY to the point where it causes the cutter to slightly pull the metal away from the table top when cutting.

Again turn this 1/4" bolt counter-clockwise 1/4 turn (which in effect eliminates any pulling of metal).

Finally turn the spring-loaded 1/4" bolt clockwise ONLY to the point where there is a slight tension on the spring. THIS SPRING MUST NOT BE TIGHT.

Turn off-on switches on MAGNO-PAK units off when these units are not being used to hold metal on the table.

Applications

Refer to "Application" bulletin, No. SMA 2957, for methods and applications of the SHOPMASTER.

INSTRUCTIONS

Adjustment of Cutter Wheels:

The overlap of $23/64$ " of the two cutting wheels would not be changed in following the instruction above set out since no change was necessary in rotating the adjuster bushing, 40-2.

The clearance between the upper cutter wheel and the lower cutter wheel, however, must be adjusted to .002 where these cutter wheels overlap. This is accomplished when the Allen Socket Head Cap Screw, F-9, is loose to release the adjuster bushing, 40-2, by tapping either the $1/2$ " hex nut, F-2, or the cutter bolt, 40-4-1. Use feeler gauge to check clearance. (Caution: To avoid damaging the cutting edges of the cutter wheels, remove "V" belt from pulley, P-2, and propel cutters by hand to make sure that cutting edges of cutter wheels do not bind or come in contact with each other at any point during a complete rotation of the cutter wheels).

After clearance is established, lock adjuster bushing, 40-2, by turning Allen Socket Head Cap Screw, F-9, Clockwise.

Lubricate sprockets and chains and re-install the back chain guard, 400-4, and the front chain guard, 400-5.

ADJUSTMENT OF MOTORIZED CUTTERS ON CUTTER TRACKS

Our motorized cutters are designed to travel along the straight cutter tracks in a self-aligning manner and to effect straight cutting of metal. To assure this travel for straight cutting, the $1/4 \times 1 1/2$ " round head stove bolt, F-36, is set at the factory so that the cutter will travel in a straight line without pulling or pushing metal on or off of the table, and no further adjustment of this bolt should be required in the field. If, however, this bolt does drift out of adjustment, turn this stove bolt, F-36, gradually clockwise to the point where the cutter slightly pulls the metal away from the table when cutting, and then gradually turn the same bolt counter clockwise to the point where any pulling of the metal is eliminated in a cutting operation. Finally, turn the spring loaded 1.4×3 stove bolt, F-6, clockwise only to the point where there is a slight tension on the spring, S-2.

Note: This spring must not be tight.

Objectives: To change motorized cutter wheel from one side (cutting edge) to opposite side (cutting edge) and to adjust cutter wheels

Refer to the schematic sheet entitled "COMPLETE ASSEMBLY #400-1".

Remove the back chain guard, 400-4, secured to the cutter frame with bolts, F-36 and the front chain guard, 400-5, secured to the cutter frame with bolts, F-35.

Caution: In following these instructions, be sure to handle cutter wheels with extreme care to avoid chipping or damaging the cutting edges.

Remove Upper Cutter Wheels, #40-1:

Loosen adjuster bushing, 40-2, by turning the Allen Socket Head Cap Screw, F-9, counter-clockwise and tap the ½" hex nut, F-2 until the upper cutter wheel, 40-1, is separated approximately 1/16" from the lower cutter wheel, 40-1. (This is done to avoid damaging cutting edges of either of the wheels.)

Loosen and remove the ½" hex nut, F-2 (Use two wrenches – one on cutter bolt, 40-4-1, and another on hex nut, F-2).

Slide cutter bolt, 40-4-1, out gradually until the cutter wheel sprocket, G-5, with chain, 40-9, is removed from the cutter bolt.

Remove cutter bolt, 40-4-1, from the cutter wheel bearing, B-6, as well as the shim, W-3, and the upper cutter wheel, 40-1, from the wheel bearing, B-6, as well as the shim, W-3, and the upper cutter wheel, 40-1. (We suggest placing all these parts on a piece of wrapping paper in the same sequence shown on the schematic parts sheet).

Remove Lower Cutter Wheels, #40-1:

Remove ¼ x 3 round head stove bolt, F-6, with washers, W-2, and spring, S-2, and swing cutter assembly at a right angle to the back plate, 400-3.

Loosen and remove ½ hex nut, F-2. (Use two wrenches – one on cutter bolt, 40-4-2, and another on hex nut, F-2).

Slide cutter bolt, 40-4-2, out gradually until cutter wheel sprocket, G-5, with chain, 40-10, and bronze worm gear, G-3, are removed from the cutter bolt. Remove cutter bolt, 40-4-2, from the cutter wheel bearing, B-6, as well as the shim, W-3, and the lower cutter wheel, 40-1, from the cutter bolt. (We suggest placing all these parts on a piece of wrapping paper in the sequence shown on the schematic parts sheet).

Clean all parts thoroughly.

Turn each of the cutter wheels to change from one side (cutting edge) to the opposite side (cutting edge) and slide onto the respective cutter bolts (40-4-1 and 40-4-2).

Install the components on each of the cutter wheel assemblies in reverse sequence of the explained above. (Be sure the cutting edges are always in the clear. Use a light piece of cardboard between the cutting edges where necessary to avoid possible damage to the cutting edges).

ADJUSTMENT INSTRUCTIONS FOR SHOPMASTER CUTTERS

Alignment of cutters on their tracks

(This sheet is to be used with DWG. SMC82564)

1. Place full length sheet of metal (120" – 10' unit and 96" – 8' unit) as shown.
2. Position MAGNO-PAK "D" (only) as shown.
3. Start length cutter #1 into metal and as it is making the cut place a thumb on both the sheet and the SHOPMASTER top at position "E". (This will allow the operator to feel if the metal pushes or pulls, which results in bowed cuts.)
4. If the sheet pulls in direction "X", proceed as follows:

A. Loosen Locknuts on "A" and "B".

Note: It is necessary to remove lower front side chain guard for access to the locknut on bolt "A"

B. Turn bolt "B" counter-clockwise about 1/8 turn, and tighten locknut.

C. Adjust bolt "A" until tension on the spring is just enough to return the cutter casting against bolt "B" (Push cutter #1 in direction "Z" about 1/4" from "B" to check tension on the spring.)

Note: It is not necessary to tighten the locknut on bolt "A" until final adjustments are made.

D. Cut another strip of metal, using the same procedure as above. If the sheet still pulls in direction "X", keep making adjustments until the sheet does not pull at position "E".

E. After the final adjustments have been made, tighten the locknut on "A" and replace guard. Also make sure that locknut on "B" is tight.

- 4a. If the sheet pushes in direction "Y", follow the above procedure but turn bolt "B" in a clockwise direction.
5. Cutter #2 should be adjusted in the same manner as #1.

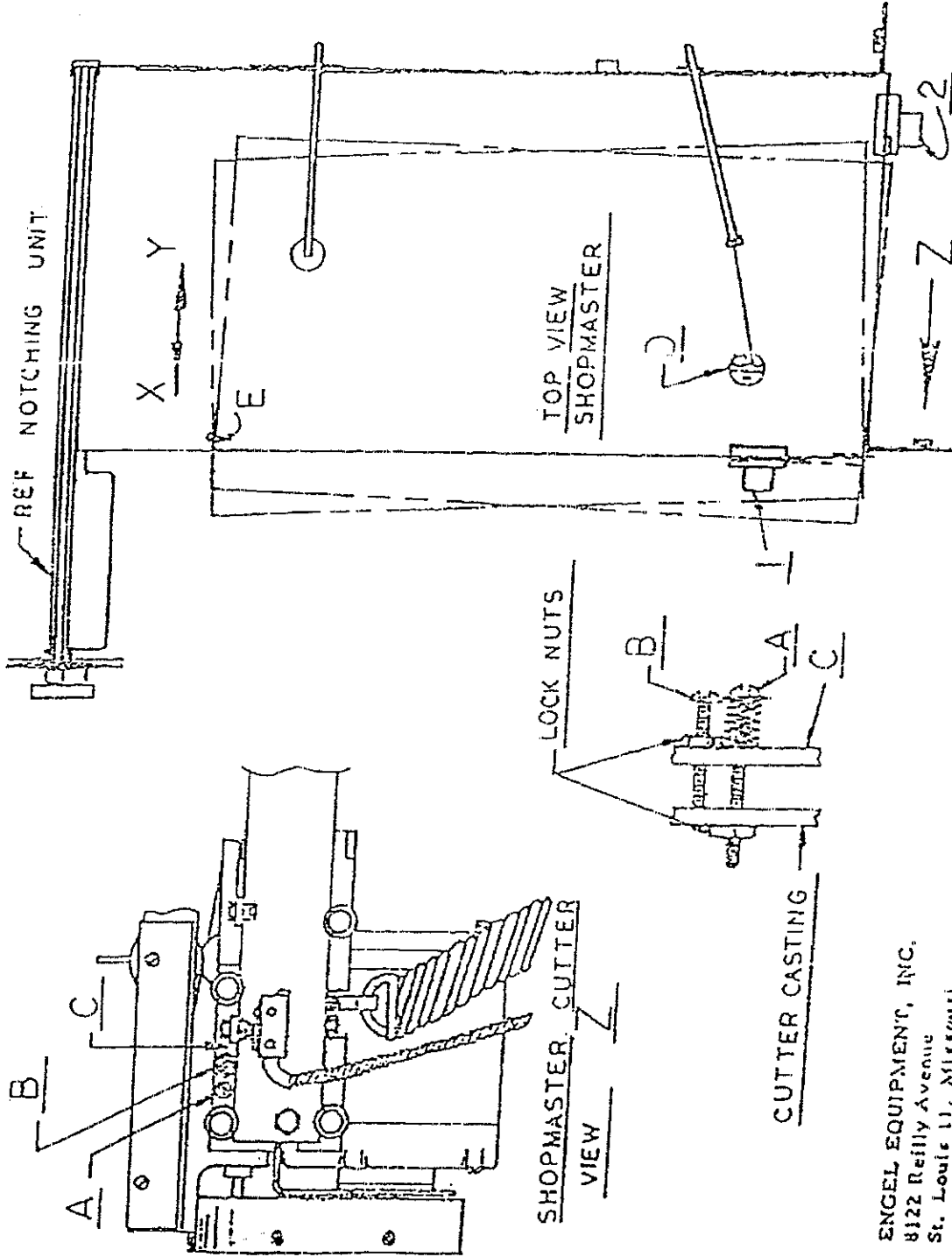

ENGEL EQUIPMENT, INC.
 8122 Reilly Avenue
 St. Louis 11, MISSOURI

SHOPMASTER LUBRICATION INSTRUCTIONS

Lubrication Prior to Starting

Remove the front cover plate on each of the cutters. Fill the lubricant well of each of the cutters to a point approximately one-half inch (1/2") above the bottom of the wells with the lubricant furnished.

Apply a few drops of lightweight lubricating oil to the two (2) small rollers at the end of the MAGNO-PAK support arms

Lubrication During Operation

Check and replenish lubricant in cutter lubricant wells approximately every 60 days with mechanic's jelly lubricant

Apply approximately three (3) drops of SAE 10 lightweight non-detergent motor oil to the cutter motors every thirty (30) days.

Apply a few drops of lightweight motor oil to the two (2) small rollers at the ends of the MAGNO-PAK support arms every thirty (30) days.

Note: For SHOPMASTERS with attached notching units, refer to "Notching Unit Lubrication Instructions"

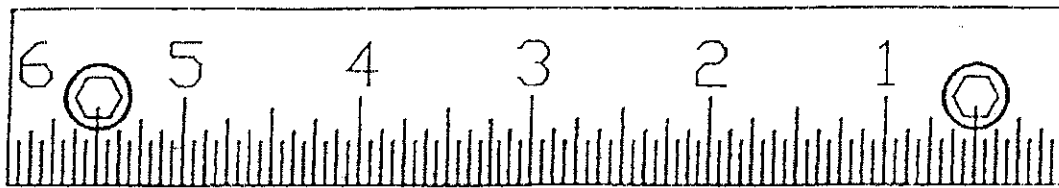

BRL

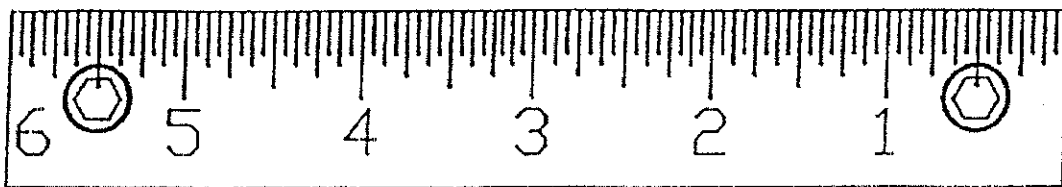

FRL

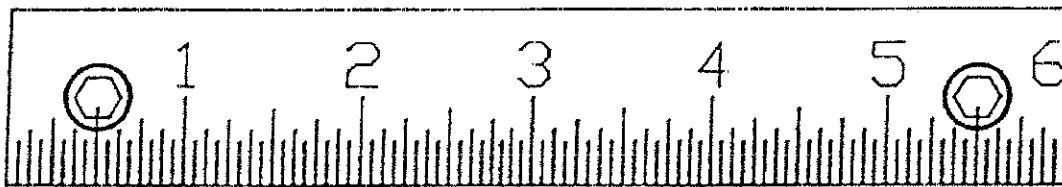

BLR

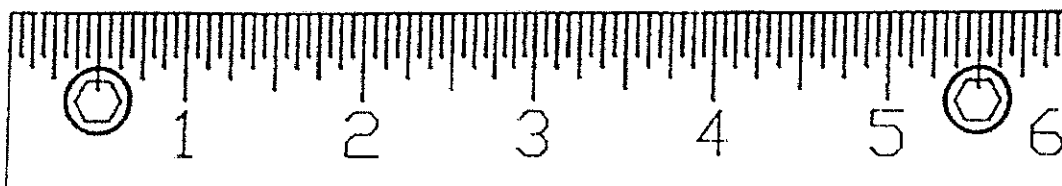

FLR

CALIBRATED STEEL BARS

Engel calibrated steel bars are accurately stamped in 1/16 inch graduations. There are four different types available in lengths of 48 inches, 96 inches and 120 inches as follows:

CUTTER WHEEL ALIGNMENT

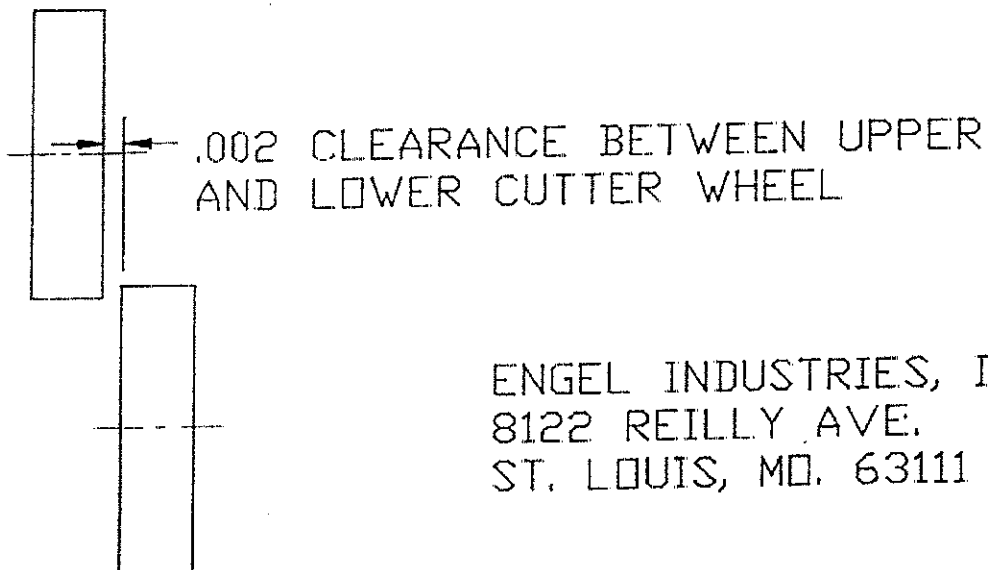
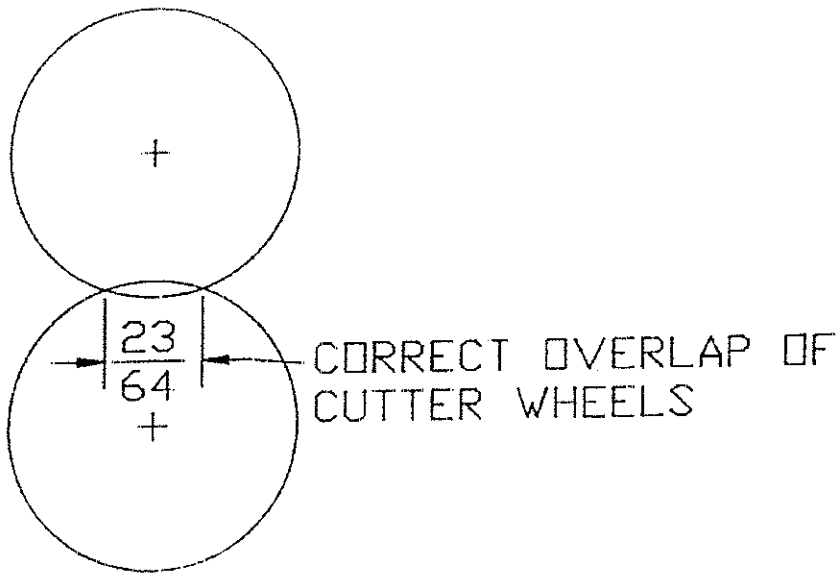

ENGEL INDUSTRIES, INC.
8122 REILLY AVE.
ST. LOUIS, MO. 63111

SHOPMASTER CUTTER ASSY.

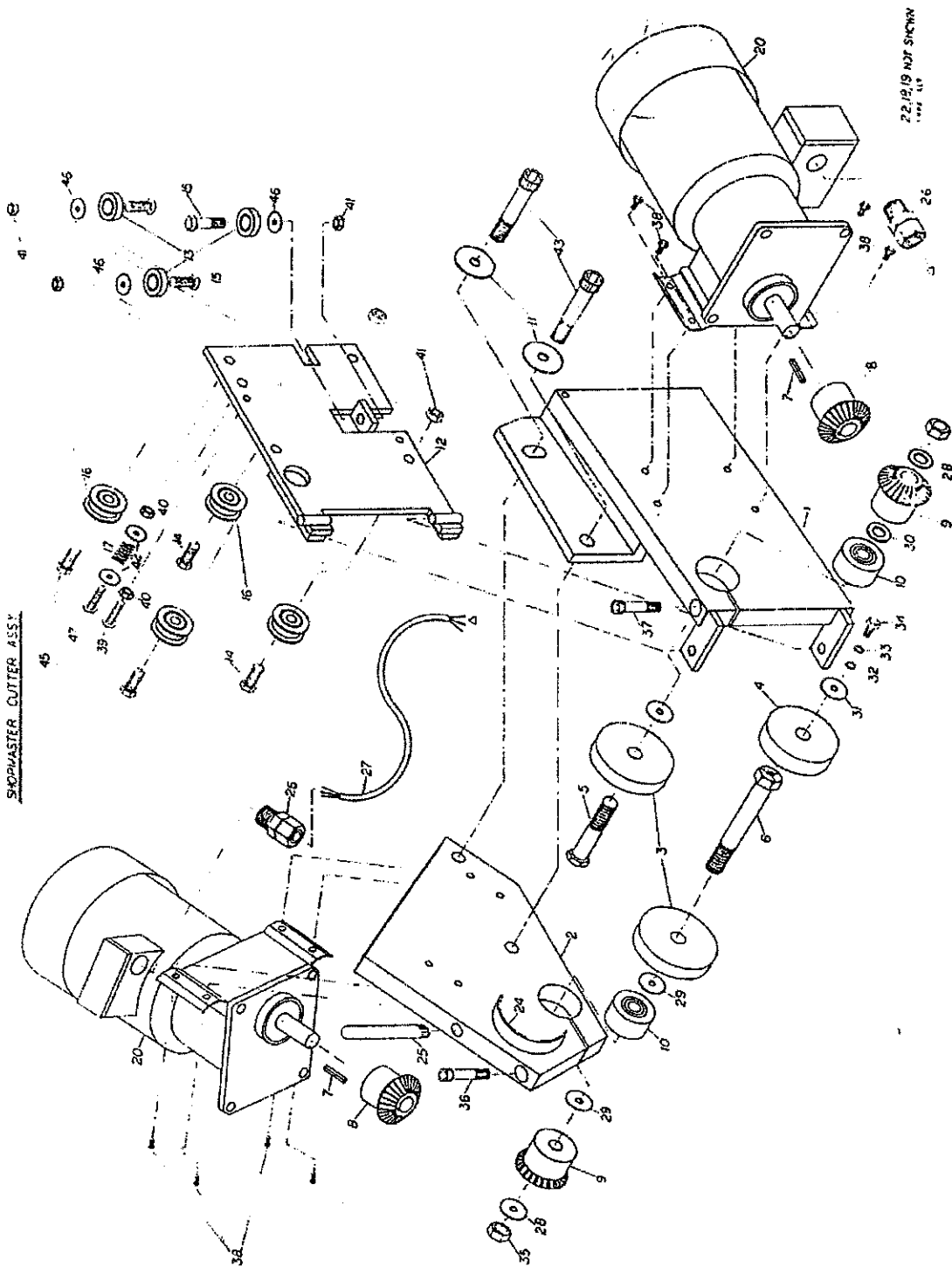

DRWG. NUMBER	Engel Part NUMBER	QUANTITY	DESCRIPTION
1	1074818	1	LOWER MOUNT PLATE ASS'Y
2	1074817	1	UPPER MOUNT PLATE ASS'Y
3	542014	2	CUTTER WHEEL
4	1843	1	TRIMMING WHEEL
5	842-2	1	LOWER SHAFT
6	842-1	1	UPPER SHAFT
7		2	1/8 X 1/8 X 1" LG KEY
8	514132	2	MITER GEAR
9	514190	2	1/2" MITER GEAR
10	511054	2	NEW DEPARTURE BEARING
11	511178	2	END CAP WASHER
12	707	1	BACK PLATE ASS'Y
13	511055	3	NICE BEARING
14	724	2	#724 CUTTER TRACK BOLT
15	725	3	#725 ECC. BOLT CUTTER
16	511171	4	TRACK BEARING
17	571017	1	SPRING
18	1068250	1	MITER GEAR GUARD-NOT SHOWN
19	1068249	1	MITER GEAR GUARD-NOT SHOWN
20	501045	2	DAYTON 1/6 HP MOTOR
21			
22	531008	1	RETRACTABLE CORD-NOT SHOWN
23			
24	1074800	1	CUTTER GUARD
25	1074802	1	HANDLE
26		2	CORD GRIPPER
27		1	SO CORD
28		2	.040 SHIM X 1/2" ID
29		2	.060 SHIM X 1/2" ID
30		1	.020 SHIM X 1/2" ID
31		1	FLAT WASHER 1/4" X 1"
32		1	FLAT WASHER 1/4"
33		1	LOCK WASHER 1/4"
34		1	HEX HEAD BOLT 1/4-20 X 1 LG
35		2	HEX NUT 1/2-13
36		1	SHCS 3/8-16 X 2-1/2" LG
37		1	SHCS 3/8-16 X 3/4" LG
38		12	1/4 X 3 RD. HD. STOVE BOLT(BACK PLATE ADJUSTER)
39		1	1/4 X 1-1/2 RD. HD. STOVE BOLT
40		2	HEX NUT 1/4"
41		3	HEX NUT 3/8
42		2	FLAT WASHER 3/8
43		2	SHCS 1/2-20 X 1-1/2" LG
44			
45		2	SHCS 3/8-16 X 1" LG
46		3	.060 SHIM X 3/8 ID

MAGNO-PAK PARTS LIST

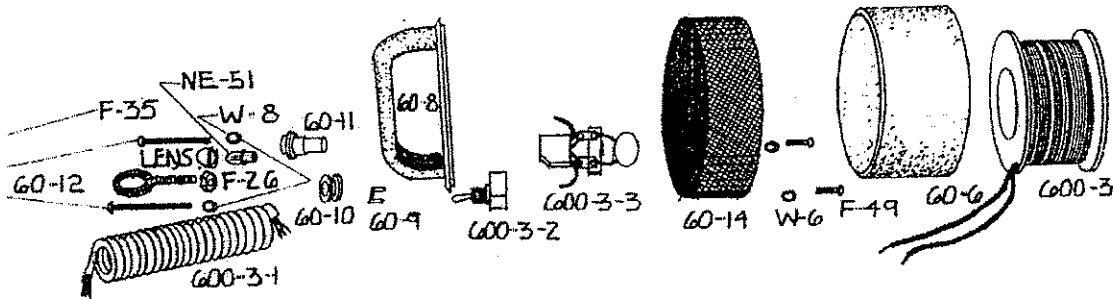

PART NO.	QTY. PER UNIT	EP NO.	DESCRIPTION
60-6	1	#1594	BOBBIN HOUSING
60-8	1	#1596	HANDLE
60-9	1		CORD RETAINING CLAMP
60-10	1	#572123	RUBBER GROMMET INSULATOR
60-11	1	#520001	PILOT LIGHT HOUSING W/LENS
60-12	1		HOOK
60-14	1	#1602	PERFORATED METAL SHIELD
600-3-1	1	M-RC	RETRACTABLE POWER CORD
600-3-2	1	#551024	SWITCH(D.P.S.T.)
*600-3-3	1	#553004	SELENIUM RECTIFIER
		#553040	VARISTOR WITH CINCH CONNECTOR
600-3-4	1	#1068846	BOBBIN W/MAGNET CORD # 531235
NE-51	1	#520032	NEON LAMP
F-26	1		NUT 1/4-20
F-35	2		1/4-20 RD. HD. SCREW X 2-1/2" LG
F-49	2		1/4-20 RD. HD. SCREW X 3/4" LG
W-8	2		1/4" LOCK WASHER
W-6	2		1/4" SPRING LOCK WASHER

* REPLACED BY #553004 + 553040

WARNING

NEVER PUT YOUR HANDS IN THE POINT OF OPERATION OF ANY MECHANICAL OR ELECTRICAL DEVICE.

IF A MACHINE IS JAMMED, NEEDS ALIGNMENTS, DIE CHANGES, ETC., ALWAYS DO A LOCK-OUT/TAG-OUT PROCEDURE, WHICH MEANS THE POWER MUST BE OFF AND LOCKED-OUT TO ENSURE SAFETY. THIS IS A FEDERAL OSHA REQUIREMENT AND MUST BE A WRITTEN AND TRAINING TYPE OF PROGRAM.