

SECTION 1

SAFETY PRECAUTIONS

Before using the Roper Whitney manual brake, carefully read and fully understand the safety precautions outlined in this section. **GENERAL PRECAUTIONS** pertain to the general workplace, and to the attitudes and work habits you bring to the job. **SAFETY PRECAUTIONS DURING OPERATION** pertain to work on the brake, and are repeated in other areas of the manual where they pertain.

Do not consider this section to be all-inclusive on the subject of safety. It is intended to be a general guide to safety practices as they pertain to the machines covered by this manual. No set of guidelines can substitute for a common sense, informed, proficient, safety-conscious attitude on your part.

Notify management or supervision when ever you feel there is any hazard involving the equipment or the performance of your job.

Never permit untrained individuals to operate this equipment without close supervision. Be sure you know and understand the task at hand, and the hazards associated with it.

Observe and follow safety instructions for your work area. Pay special attention to posted warnings, and warning labels on the equipment. Do not place speed above safety.

Wear appropriate clothing. Loose or hanging clothing or jewelry, finger rings, etc. can be hazardous. Use the appropriate safety equipment, such as eye and hearing protection, and safety-toe shoes. If gloves are worn to protect from cuts, be sure they are snug fitting and not likely to be snagged by moving equipment.

Keep the work area neat and orderly. Be sure it is well lit, that extra tools are put away, trash and refuse are in the proper containers, and dirt, chips or debris have been removed from the working areas of the machine. Be sure the floor area is clean and dry, and that extension cords and similar trip hazards have been removed.

Use the proper tools for the job. Inspect them before use to see that they are in good working condition. Replace broken or defective tools and equipment.

Use only approved cleaning materials: do not use explosive or flammable liquids to clean the machine. Discard used cleaning materials in the appropriate containers.

Do not use compressed air to clean debris, chips, dirt, or grit from the machine, or from your clothing. Remove chips and grit from the machine with a suitable brush; never with your hands.

Safety Precautions During Operation

Do not attempt to operate the brake in excess of its rated capacity. Do not attempt to form wire, nails, rods or pipe on the machine.

Avoid any pinch points created by movement of the machine's components.

Exercise care around the bending apron counterweights. Stand clear of the ends of the brake during the bend cycle or whenever the bending apron is moved. Do not loosen the set screws securing the counter weight rods while the bending apron is in the vertical position.

WARNING!

SERIOUS INJURY MAY OCCUR

The counterweight and rod can drop suddenly through the holder.

Always use the apron lift handles to apply the bending force. Under no circumstances use the counterweight rods for leverage. Failure to heed this warning can cause personal injury or damage to the counterweight rods. Always stand clear of the apron lift handle travel arc during the bend cycle to avoid being struck by the handles.

WARNING

SERIOUS INJURY MAY OCCUR

Avoid pinch points created by the clamping and bending components.

Always stand clear of clamping handles. If the brake has not been properly adjusted for material thickness; clamping action on one end of the brake may cause the opposite clamping handle to snap forward due to the twisting stress created on the upper beam. (this can also indicate that the clamping collars need adjustment. Refer to Section VII, Periodic Maintenance.)When opening the upper beam make sure the handles are moved to the horizontal position to avoid accidental forward movement of the handles -caused by the weight of the upper beam.

If you observe unusual noises or vibrations during machine operation, check the machine condition immediately. Do not attempt to operate the equipment further until the causes of unusual behavior have been found and corrected.

SECTION 2

MACHINE DESCRIPTION

Roper Whitney floor mounted manual bending brakes are precision machines for use in bending mild steel and other sheet metals, including aluminum, brass, bronze, copper, duralumin; lead, monel metal, silver, carbon and stainless steel within rated capacity.

The brakes are rated to form a 1 -inch minimum wide flange over entire length of brake on a single thickness of material of the rated gauge capacity with work angle support installed. Bending capacities are reduced by four (4) gauges when the apron work support is removed.

The machines are essentially identical in construction, varying only in length or capacity. Major components are shown in Figure 1.

Fabricated of sturdy steel plate with appropriate gussets, braces and trusses; three basic longitudinal members (upper-beam, lower-beam and bending leaf / apron) control the clamping pressure and stress incurred in overcoming the yield strength of the material being formed. Provisions for adjusting clamping force and tensioning of the longitudinal members are incorporated in the design of the bending brakes.

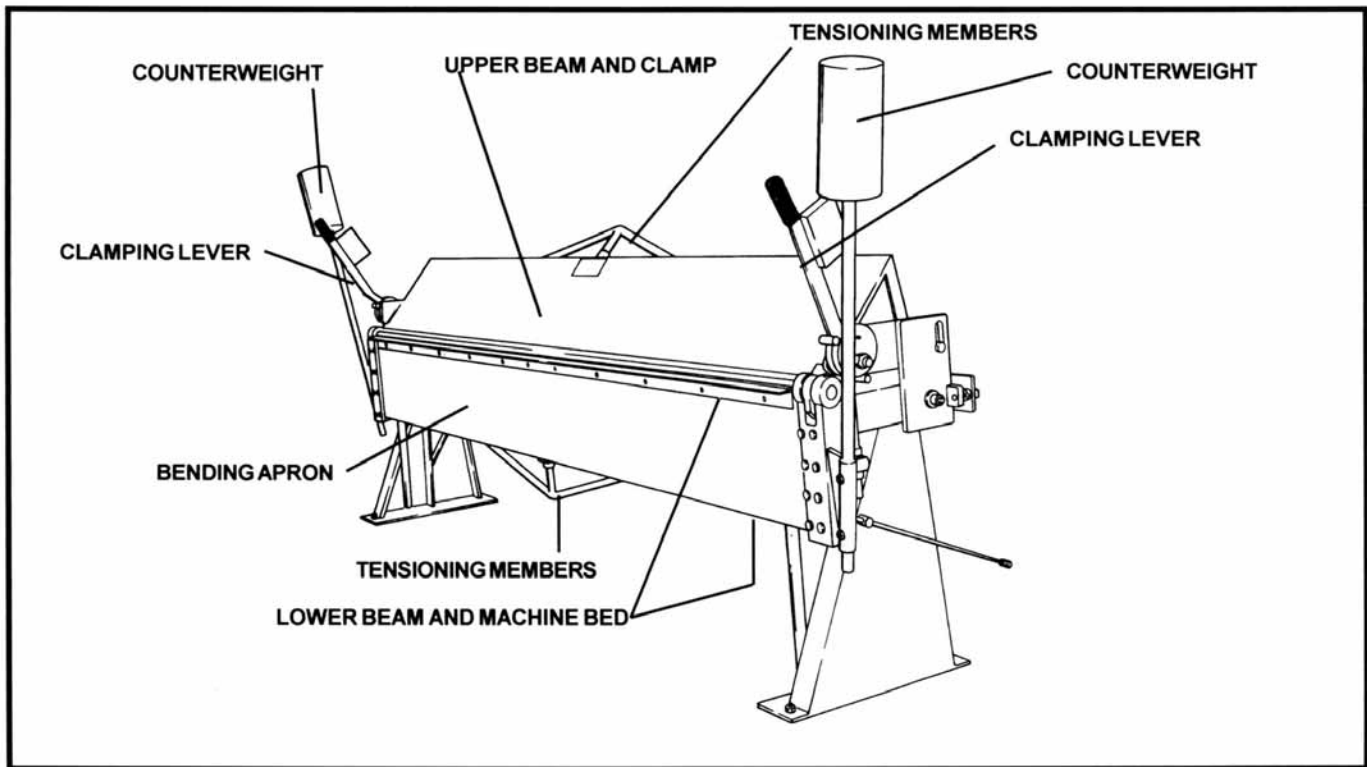

Section 3

Specifications

Feature	Model 816	Model 1016	Model 1018
Bed Length	97 in.	121 in.	121 in.
Capacity			
With bending bar and angle in place	16 Ga.	16 Ga.	18 Ga.
With bending angle removed	20 Ga.	20 Ga.	22Ga.
With bending bar and angle removed	24 Ga.	24 Ga.	26 Ga.
Minimum Reverse Bend (bending bar and angle removed)	¼ in.	¼ in.	¼ in.
Maximum lift of beam	1-5/8 in.	2-1/4 in.	1-5/8 in.
Front to Rear Adjustment of Beam	1-1/8 in.	1-3/8 in.	1-1/8 in.
Approximate Shipping Weight	1640 lbs.	2660 lbs.	2200 lbs.
Packing	Heavy wood skids and blocking with plastic cover		

SECTION 4 RECEIVING AND INSTALLATION

RECEIVING

When you receive your bending brake, check immediately for obvious damage, which may have occurred during transit, to the skidding material or to the brake itself. Also check to see that all material listed on the bill of lading is present.

Since Roper Whitney equipment is normally sold F.O.B., factory in Rockford, IL, our responsibility for transit damage ceases when the transportation company signs the bill of lading indicating it has received the items listed in good condition.

Report discovered damage or shortages to the carrier. Make a notation on the delivery waybill, and have the delivering driver sign it, acknowledging the damage or shortage.

Submit claims for repair or replacement to the carrier; include any extra shipping charges. Notify Roper Whitney Company promptly of any damage or shortages.

If you discover concealed damages or shortages after the carrier has departed, you may still file a claim for concealed damage. This should be done as quickly as possible. Again, notify Roper Whitney Company promptly of such damages or shortages.

UNLOADING

The brake is shipped on a skid of 3" x 6" wood timbers. It is secured to this skid with four (4) carriage bolts, which should remain secured while the machine is unloaded and moved about. The skid and brake may be moved using a suitable forklift.

WARNING

WHEN IN MOTION, THE SKIDDED BRAKE MAY BE TOP HEAVY

When lifting or moving the skidded brake with a forklift, secure the brake laterally to the forklift.

UNPACKING

The two counterweight arms (rods) and their counterweights are mounted separately on the wooden skid for shipment. Remove these from the skit and set to one side.

WARNING

THE COUNTERWEIGHT ARMS AND COUNTERWEIGHTS ARE HEAVY

Use care when removing them from the skid to avoid injury.

The clamping handles at each end of the brake are wrapped and wired in the down position to prevent damage and to prevent the handles from being used to move the brake. Remove the wires and wrapping.

Wooden blocks are positioned between the upper and lower beam jaws to prevent damage during shipment. Lift the clamping handles and remove the blocks.

The bending leaf (apron), is wired to the center truss stud of the lower beam to prevent movement during transit. Remove the wire.

Remove the four (4) carriage bolts, nuts, and washers securing the brake to the skidding. **DO NOT REMOVE THE BRAKE FROM THE SKID AT THIS TIME.**

WARNING AND CAUTION

SERIOUS INJURY CAN RESULT OR THE BENDING BRAKE CAN BE DAMAGED

Do not operate the brake on the skid. The brake must be attached to the floor. The machine is top heavy and can tip if not securely anchored. The skid does not provide a suitable anchoring platform.

SITE PREPARATION

The brake must be placed on a firm floor which does not sag and which does not have any "spring" to it. The floor must be generally level, with no twisting or unevenness in the surface. The floor must also be capable of accepting 1/2-inch lag screws or bolts for the purpose of securing the brake.

There must be adequate area around the brake for free movement of the operator and the handling of large sheets of metal. Allow 4 to 6 feet behind the brake, 6 to 8 feet in front of the brake, and 3 feet on either end of the brake.

To move the brake off the skid, and to its mounting position, use an overhead crane or a forklift with the forks above the brake. If a forklift is used, secure a lifting hook on the lift forks. Pass a sling under brake and secure each end on the lifting hook as shown in Figure 2.

CAUTION

THE BENDING BRAKE CAN BE DAMAGED

Do not move the brake using lift truck forks directly under any machine members.

SETTING THE BRAKE

Using the overhead crane, lift the brake from the skid and place it in its desired location. Be sure the brake is properly balanced.

WARNING

THE BRAKE TENDS TO BE TOPHEAVY AND CAN TWIST IN THE SLING

Use care when moving the brake from the skid to avoid injury.

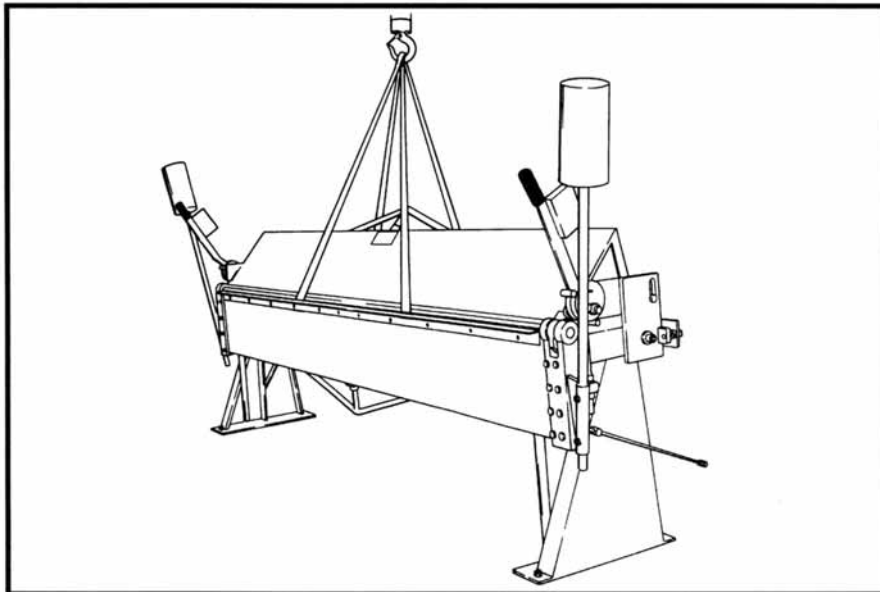

LEVELING THE BRAKE

Raise the upper beam to its maximum height using the eccentric lifting levers. See Figure Place an accurate spirit level on the bed at each end of the bed bar.

Shim under the legs of the brake until the bed bar shows the machine is level front-to rear. This will remove any twist from the bed. Side-to-side leveling is not necessary to proper operation of the brake.

ANCHORING THE BRAKE

Anchor the leveled brake to the floor using 1/2-inch lag screws or bolts through the leg mounting holes. Tighten securely, making sure pressure is exerted on the leveling shims.

INSTALLING THE COUNTER WEIGHTS

Have an assistant raise the bending apron to the horizontal position, and hold it in that position while the counterweights are installed.

Install a counterweight in the mounting hole in each end of the bending apron. Adjust the counterweights so that they balance the bending apron in the horizontal position.

Tighten two set-screws securely on each counterweight shaft.

WARNING

THE COUNTERWEIGHTS ARE HEAVY

Use care when installing the counterweights to avoid injury. Be sure the set screws are tightened enough so the counterweights will not drop when the bending apron is returned to the vertical position.

SECTION 5 SETUP

The machine has been adjusted and pretensioned at the factory. Set-up adjustments are for clamping pressure, material thickness, setting up for narrow or offset bends, setting bend angle control, and setting up of the optional rear material stops.

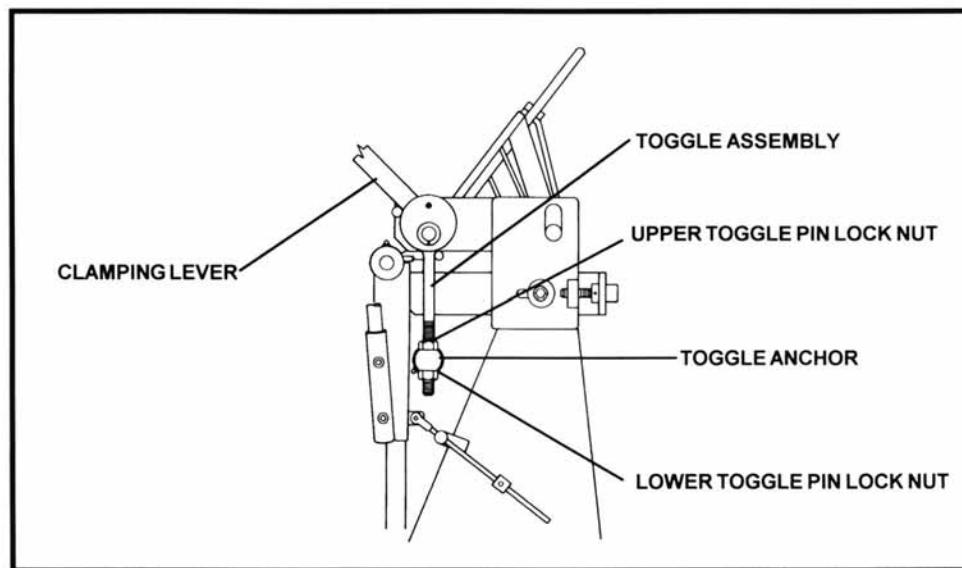

SETTING CLAMPING PRESSURE

Excessive clamping pressure is not required or desirable. It has a tendency to counteract the normal preloading adjustments and may interfere with obtaining straight and uniform bends. Use only enough clamping pressure to keep the material from slipping.

Be sure the gauge thickness of the material to be formed to is within the rated capacity of the machine. Then adjust clamping pressure as follows:

1. At each end of the brake, loosen both toggle pin lock nuts slightly before beginning adjustment (see Figure 3).
2. Place small sample pieces of the material to be formed between the upper beam radius bar and the bed at each end of the machine. Clamp in position.
3. At each end of the machine, tighten the lower toggle pin lock nut against the toggle anchor just enough to hold material firmly when the clamping lever is against the forward stop (see Figure 3).
4. At each end of the machine, tighten upper toggle pin lock nut against the toggle anchor (see Figure 3).
5. At each end of the machine, pull the clamping lever forward against the stop. Each end should require equal effort. Adjust one end, if necessary, according to the general procedure above.

ADJUSTING FOR MATERIAL THICKNESS

Under normal circumstances, clearance between the apron edge and the upper beam radius bar should be approximately (2) times the material thickness for 16 ga. mild steel. For lighter gauge material, less clearance is required. One and a half (1-1/2) times material thickness is usually sufficient. Soft material, such as aluminum, may be formed with a clearance equal to the material thickness.

CAUTION

THE BENDING BRAKE CAN BE DAMAGED

Clearance must never be less than the material thickness.

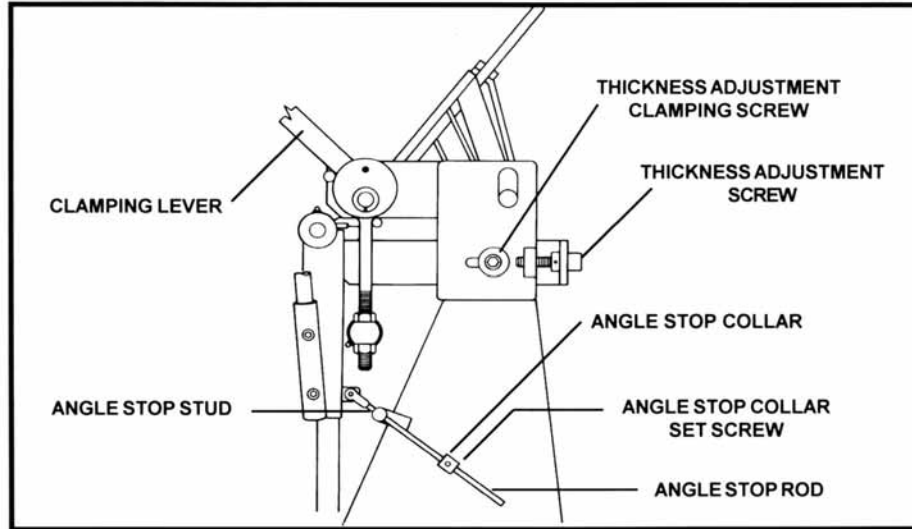

Make the adjustment as follows:

1. With the upper beam lowered to the normal operating position, but not clamped tightly against the bed, loosen the thickness adjustment clamping screws located on both ends of the brake (see Figure 4).
2. Raise the apron to the 90-degree position.
3. Move the upper beam forward or back until proper clearance is achieved by turning the thickness adjusting screw located at rear of the leg bracket on each end of the machine (see Figure 4). Final adjustment must always be toward the front of the brake to remove backlash from the adjusting screws.
4. Retighten the clamping screw on each end of the machine (see Figure 4).

SETTING UP FOR NARROW OR OFFSET BENDS

It is sometimes necessary to remove the bending reinforcing angle to make narrow or offset bends. In extreme conditions, it may also be necessary to remove the bending bar. The bending bar is made of tough, wear resistant material to protect the edge of the apron and should be removed only when absolutely necessary to make tight reverse bends.

Removing the bending reinforcing angle reduces capacity by four (4) gauges. The rated 16 ga. capacity is reduced to 20 ga. capacity. Removing both the bending reinforcing angle and the bending bar reduces the 16 ga. capacity to 24 gauge capacity.

Remove the bending reinforcing angle and the bending bar as follows:

1. Support the bending reinforcing angle and remove retaining screws. Withdraw the angle from the machine (see Figure 5).
2. Support the bending bar and remove retaining screws. Withdraw the bar from the machine (see Figure 5).
3. After the bending operation is complete, be sure to replace the removed components, attaching them with the retaining screws. Tighten the screws securely.

SETTING UP THE BEND ANGLE STOP

The bend angle stop can be adjusted for multiple or precision bends. Adjust the angle stop as follows:

1. Loosen the angle stop collar set screw and move the angle stop collar out toward the end of the angle stop rod. (See Figure 4.)
2. Have an assistant move the apron to the desired position and hold it while you adjust the collar. Be sure to take spring-back into account when setting the angle.
3. Move the angle stop collar against the angle stop stud and tighten the angle stop collar set screw to retain it in that position.

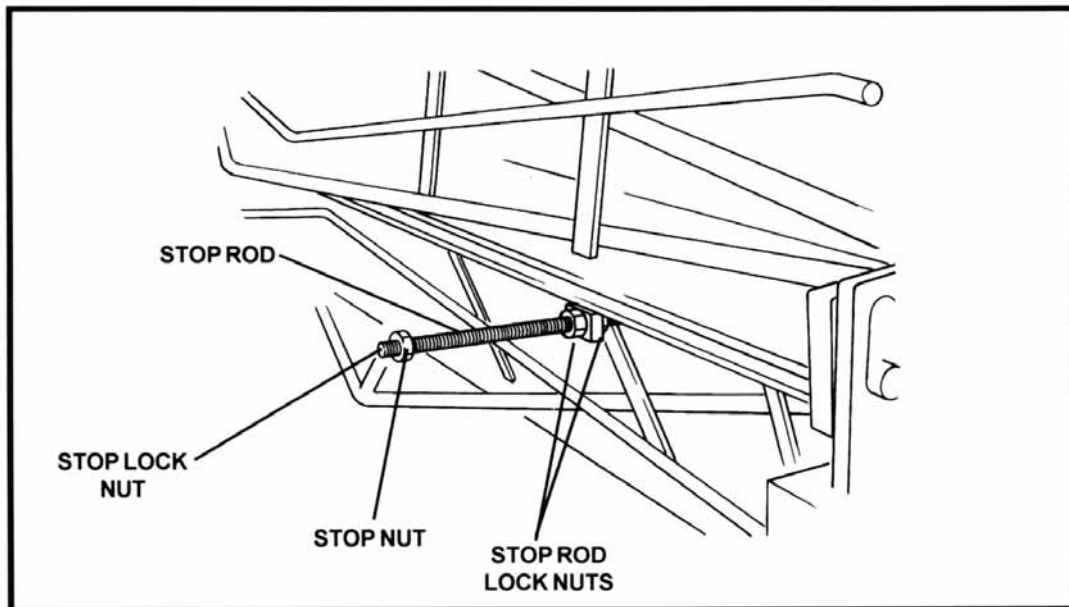

SETTING UP THE OPTIONAL REAR MATERIAL STOPS

For repeat operations involving deeper bends, it may be useful to use the optional rear material stops.

Install and adjust the rear material stops as follows:

1. At each end of the machine, insert a threaded stop rod. Secure the stop rod using the stop rod lock nuts (see Figure 6).
2. Adjust a stop nut on each stop rod to the desired position. Be sure that both stop nuts are the same distance from the front of the machine. (Angular bends not perpendicular to the material edges can be made by off setting one stop nut from the other. This will reduce the overall width which can be bent.) (See Figure)
3. Lock each stop nut in place using a stop lock nut (see Figure)

SECTION 6 OPERATION

GENERAL INSTRUCTIONS

Operation of the brake is entirely manual, and the operator has full control of the operation at all times.

Do not attempt to operate the brake in excess of its rated capacity. Do not attempt to form wire, nails, rods or pipe on the machine.

If you are bending large sheets of material which are difficult to handle, you may wish to use an assistant to help in loading, clamping, and bending.

If you observe unusual noises or vibrations during machine operation, check the machine condition immediately. Do not attempt to operate the equipment further until the causes of unusual behavior have been found and corrected.

WARNING

PINCH POINTS CAN CAUSE SERIOUS INJURY

Avoid any pinch points created by movement of the machine's components.

CLAMPING THE MATERIAL

Insert the material to be bent under the upper beam clamping mechanism, lining up both sides so they arc even with the upper beam. Position short pieces of material in the center of the brake to equalize strain during bending.

Clamp the material by lowering the upper beam with the clamping levers.

If the brake has not been properly adjusted for material thickness; clamping action on one end of the brake may cause the opposite clamping handle to snap forward due to the twisting stress created on the upper beam.

When opening the upper beam make sure the handles are moved to the horizontal position to avoid accidental forward movement of the handles caused by the weight of the upper beam.

WARNING

THE UPPER BEAM CLAMPING MECHANISM CAN CAUSE SERIOUS INJURY

Always stand clear of clamping handles. Do not place fingers near or under the upper beam.

BENDING THE MATERIAL

Bend the material to the desired bend angle using the apron lift handles to apply the bending force. Under no circumstances use the counterweight rods for leverage.

If the material being bent is long and protrudes from the machine, lift it during the bending operation to avoid creases or crimps caused by material weight.

WARNING

THE COUNTERWEIGHTS AND CLAMPING HANDLES CAN CAUSE INJURY

Always stand clear of the ends of the brake during the bend cycle.

Always stand clear of the apron lift handle travel arc during the bend cycle.

CAUTION

THE COUNTERWEIGHT RODS CAN BE DAMAGED

Using the counterweight rods to apply bending force can damage them.

BENDING OF MULTIPLE THICKNESSES

To avoid adjusting for every piece on a run of parts, do all the single-thickness bending operations first, then adjust and do the multiple thickness bending.

Never bend against hems or seams until an adjustment has been made to compensate for the clamping of multiple thicknesses of material. Never bend against hems or seams until the upper beam is setback for clearance of the multiple thicknesses of material. See SETUP, SECTION 5, for adjustment instructions.

CAUTION

MACHINE COMPONENTS CAN BE DAMAGED

Failure to compensate for multiple thicknesses of material may result in breakage of the clamping mechanism.

Failure to set the upper beam back for extra clearance may result in indentations on the upper beam jaw.

HEMMING

Hemming is the most difficult operation to control accurately on a hand brake.

Hemming creates pressure loads on the machine different than those created by regular bending, and optimum results will not be obtained using the same machine preloading for both hemming and bending.

In factory tests, closing 24 Ga. material all the way along was done easily with no change in the preloading settings used for bending. 22 Ga. material was open about 1/32 inch in the middle and hems in 20 Ga. had an opening in the middle of just under 1/16 inch under like conditions.

If you must have tight hems in material heavier than 24 Ga., do all of the bending first, adjust the machine for hemming, and close the hems in a second operation.

HEMMING... .. THE TRADITIONAL METHOD

Hemming is traditionally done by making a maximum bend of about 135 degrees and flattening it between beam and bed by lowering the clamping levers.

This approach may require additional preloading in order to close the hem tightly at the center. Increase the preload by tightening the upper beam tensioning adjusting nut (see Figure 9).

It also requires reducing clamping pressure to allow for multiple thicknesses of material. Reduce clamping pressure by slackening the lower toggle pin adjusting nut and tightening the upper toggle pin adjusting nut (See Figure 10).

HEMMING... .. ANOTHER WAY

Remove the workpiece from the machine after bending. Close the machine by clamping the beam down on the bed with the clamping levers. Place the workpiece on the front surface of the upper beam. Swing the apron up and close the hem by squeezing the workpiece between the machined surface of the apron and the upper front surface of the radius bar.

This may feel awkward at first, especially if you are accustomed to hemming in the traditional manner, but it will get easier with practice and the end result is far superior to the traditional way.

It may be necessary to move the upper beam 1/8" to 3/16" to the rear to allow clearances for the hem between apron and front of beam. See SETUP, SECTION 5, for adjustment instructions.

SECTION 7

PERIODIC MAINTENANCE

LUBRICATING.... ROTATING COMPONENTS

Grease fittings are provided for rotating components where wear may occur. Use a medium weight bearing grease, such as SAE No. 30, and grease weekly when the brake is being used. The rotating components are: the clamping lever assembly, the apron hinge assembly (2 fittings), and the toggle pin bushing. One set of these components is found on each end of the machine. Location of these fittings is shown in Figure 7.

.... SLIDING COMPONENTS

Grease sliding components weekly as well, using general purpose grease, or equivalent. These components include the clamping pin bushings and the slots in which they ride (see Figure 7).

.... ADJUSTING NUTS AND SCREWS

The upper and lower beam tensioning screws (see Figure 8) are under heavy load and must not be allowed to run dry. Keep them lubricated with an anti-sieze compound.

If the machine is frequently readjusted, the lower apron tensioning lock nut (see Figure U), and upper beam tensioning lock nut, and the lower beam tensioning locknuts (see Figure 8), they should be kept lubricated with an anti-sieze compound.

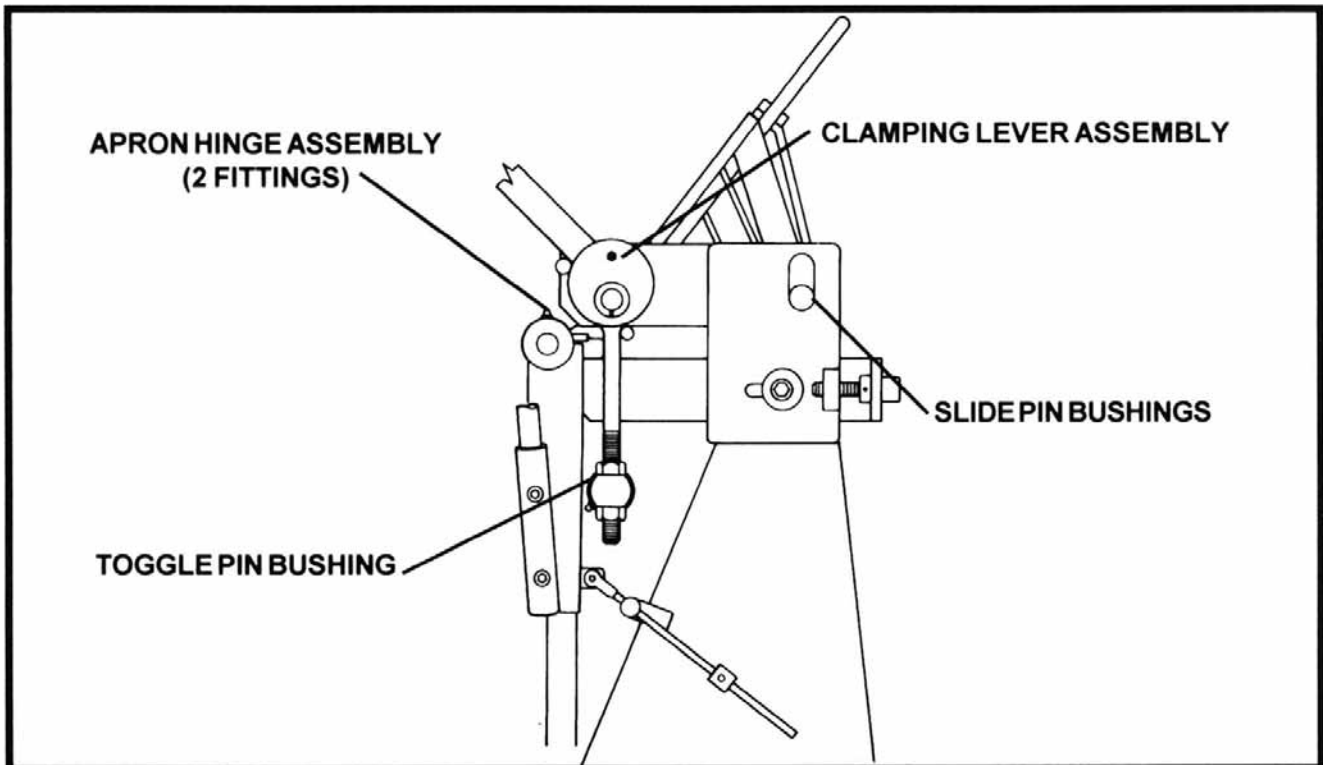

ADJUSTING THE CLAMPING COLLARS

The retaining system used to hold the clamping levers in the open position require periodic adjustment. Adjust the collars using the following procedure:

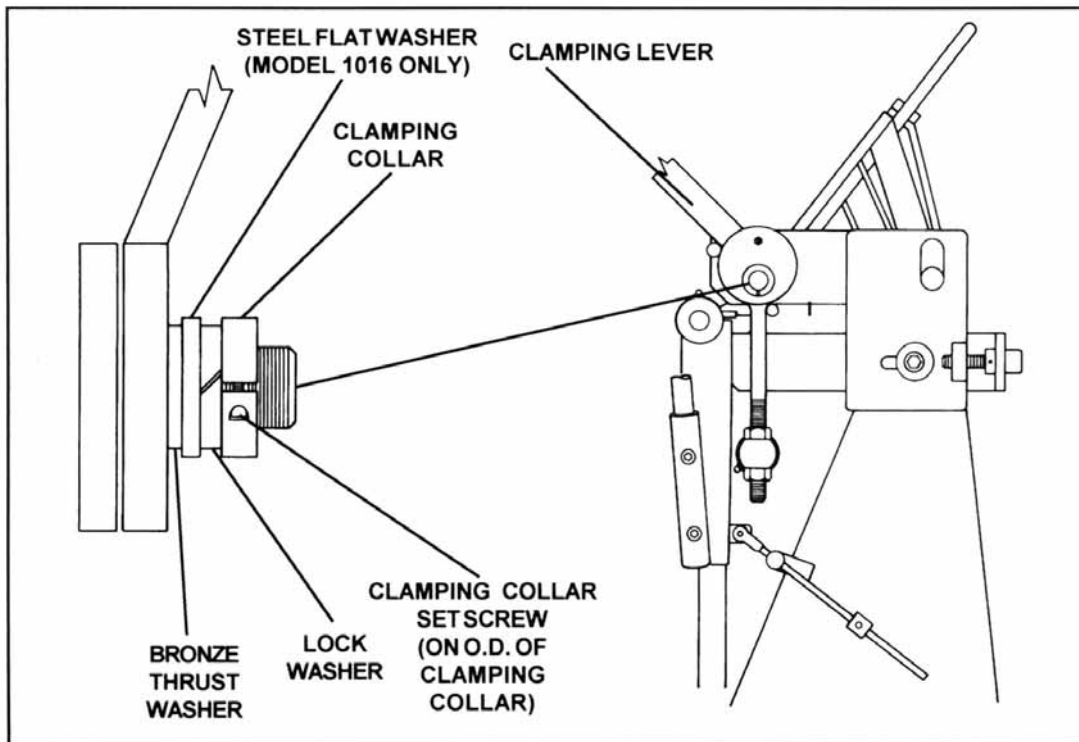

1. Slightly loosen the set screws retaining the clamping collars on each end of the machine. Set screws should be loose enough to permit adjustment of the clamping collars, but not so loose as to permit loss of position on the clamping collars when the clamping levers are moved.
2. Tighten the clamping collars by turning them clockwise, until you are unable to move the clamping levers to clamp material.
3. Back off the clamping collars by turning them counterclockwise until you can move the clamping levers to clamp material. The collars are properly adjusted when one lever can be unclamped, and the lever at the opposite end of the machine remains clamped. It may require several adjustments at each end of the machine to achieve the proper tension. During these adjustments, be sure the set screws remain tight enough to prevent loss of position by the clamping collars when the clamping levers are moved.
4. When the collars are properly adjusted, tighten the set screws securely to retain the clamping collars in place.

SECTION 8 MAINTENANCE ADJUSTMENTS

BRAKE CROWNING ADJUSTMENTS

When the machine does not bend properly, it is sometimes necessary to readjust the crown on the beams. Use the following procedure:

1. Relieve all tension on the upper beam tensioning nuts and on the upper beam tensioning screw (see Figure 9).
2. Lower the upper beam onto the bed. Loosen lower toggle pin adjusting nut until there is 1/4-in. of space between bottom of the toggle anchor and the lower toggle pin adjusting nut (see Figure 10).
3. Adjust the upper beam and lower beam tensioning screws finger tight; and then tighten each with a wrench approximately one full turn (five flats) (see Figure 9).
4. Adjust the upper beam tensioning nuts finger tight, and then tighten each with a wrench approximately one full turn (five flats) (see Figure 9).
5. When looking from the rear of the brake, the upper beam and the bed should be in contact at the center and showing a crack of light at each end (see Figure 11). If less light shows at one end, loosen the rear floor bolt at that end and shim under the leg until the light shows evenly at both ends.
6. Tighten the lower toggle pin adjusting nut against the bottom of the toggle anchor (see Figure 11).

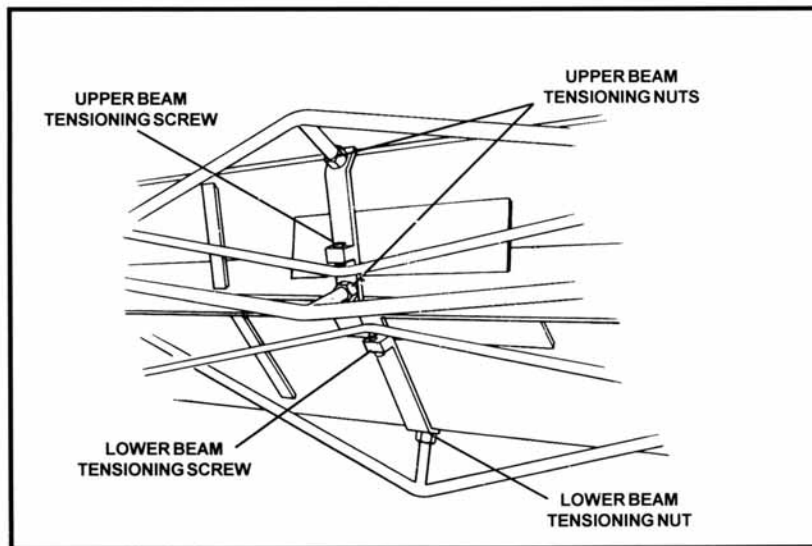

Figure 9. Upper Beam and Bed Tensioning Components

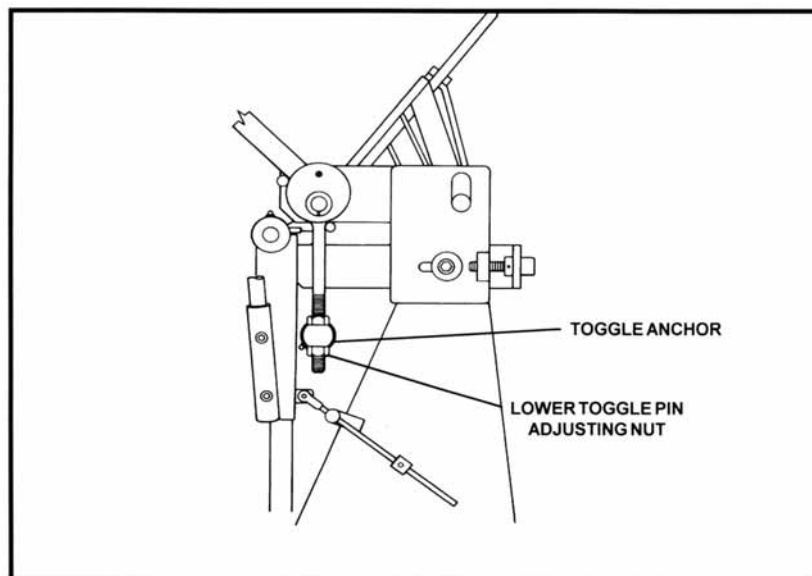

Figure 10. Upper Beam Clamp Adjusting Components

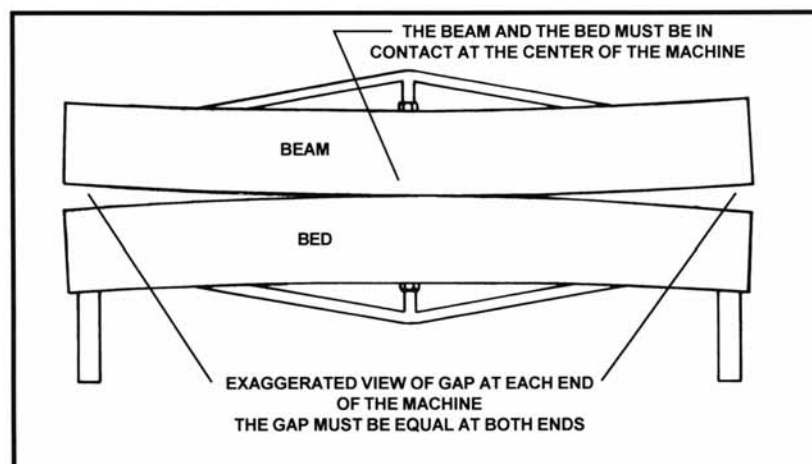

Figure 11. Proper Clearance Between the Upper Beam Clamp and the Bed

PRELOADING ADJUSTMENT

Once the brake crown has been set, the brake must be adjusted to produce straight bending and a uniform radius. Follow the procedure below:

1. Loosen the apron tensioning nuts on the apron, (see Figure 12) and the upper and lower beam tensioning nuts (see Figure 9). **On the Model 1016 brake** also loosen the apron stiffener adjusting nut located behind the lower apron tensioning adjusting nut (see Figure 12).
2. Loosen the upper and lower beam tensioning screws (see Figure 9).
3. Raise the upper beam to its maximum open height
4. Check the top edge of apron in relation to the top surface of the bed. The top edge of apron must be 1/64-in. below the top surface of the bed at each end. If not, loosen the hinge bolts and adjust the apron up or down using the apron jack screws (see Figure 13). After the apron edge is adjusted to the proper position, be sure to retighten the hinge bolts.
5. Tighten the apron stiffener adjusting nut until the apron edge is 1/32-in. above the bed edge at the center (see Figure 12). The apron edge should remain 1/64-in. below the bed edge at both ends.
6. Adjust the upper and lower beam tensioning screws finger tight; and then tighten each with a wrench approximately one full turn (five flats) (see Figure 8).
7. Tighten lower beam tensioning nut until the edge of the bed is 1/64" above the top edge of the apron at the center (see Figure 9). The edges of the bed and apron will then be parallel from end to end, with the edge of the bed 1/64" higher than the apron edge. **On the Model 1016 brake** tighten the apron stiffener strap bolt located behind the lower apron tensioning nut until the horizontal gap between the bed and apron is slightly greater in the center than at the ends (see Figure 12). It may then be necessary to back off the lower apron tensioning nut slightly to maintain the bed 1/64-in. higher than the edge of the apron.
8. Tighten upper and lower beam tensioning nuts finger tight; and then, using a wrench, tighten each from 1/4 to 1/2 turn.

The bending brake is now properly adjusted for its rated gauge capacity in mild steel.

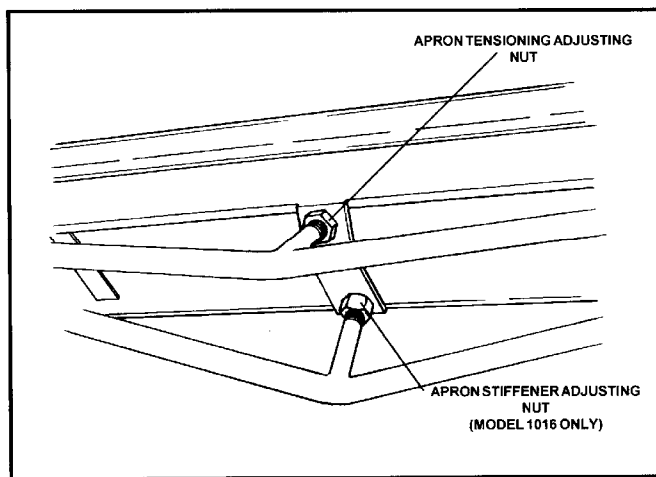

Figure 12. Preloading Adjusting Components

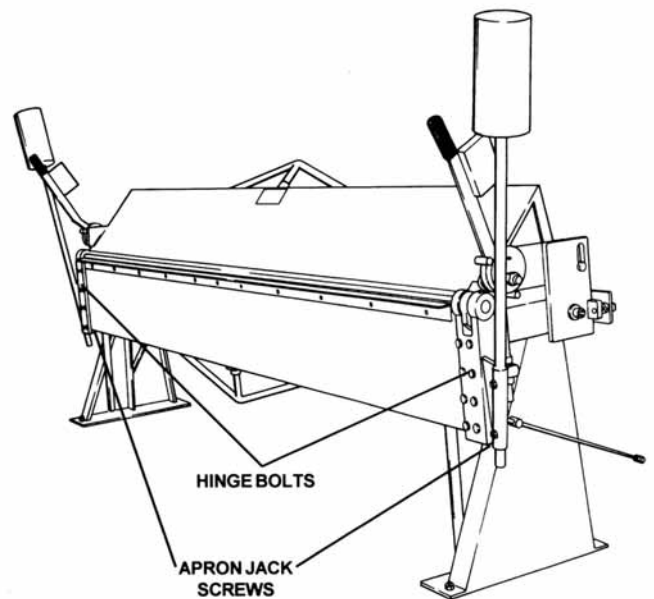

Figure 13. Apron Adjusting Components

SECTION 9 REPAIR PARTS

The table below identifies parts which may be replaced on the Roper Whitney manual bending brake. Parts may be ordered directly from our Roper Whitney distributor. If you have no distributor in your area, you may order the parts directly from the company. Common hardware items such as screws and nuts may be purchased locally, so long as the items purchased are of equivalent quality to those originally supplied with the machine.

The **Ref No.** column is keyed to the exploded view on the facing page. The **Part Number** columns provide part numbers for replacement parts for each model brake covered by this manual. The **Part Name** column provides a short descriptive name for each replacement part. The **Qty.** column identifies the quantity required for replacement.

ReE No.	Part Number			Part Name	Qty.
	Model 1018	Model 1016	Model 816		
1	257020009	257020003	257020006	Apron Assembly	1
2	757030029	757030029	757030013	Bending Bar	1
3		613012131		Screw, Flat Head, 5/16-18 by 3/4	21
3	613012131		613012131	Screw, Flat Head, 5/16-18 by 3/4	17
4	757180028	757180028	757180012	Bending Angle	1
5	657012641	657012641		Cap Screw, Hex Head, 1/2-13 by 1-3/4	11
5			657012641	Cap Screw, Hex Head, 1/2-13 by 1-3/4	9
6	679033107	679033107		Washer, Lock, 1/2-inch	11
6			679033107	Washer, Lock, 1/2-inch	9
7	457500069	457500007	457500069	Hinge Assembly, right hand	1
8	457500070	457500008	457500070	Hinge Assembly, left hand	1
9	657012641		657012641	Cap Screw, Hex Head, 1/2-13 by 1-3/4	12
9		657012641		Cap Screw, Hex Head, 1/2-13. by 1-3/4	16
10	679033107		679033107	Washer, Lock, 1/2-inch	12
10		679033107		Washer, Lock, 1/2-inch	16
11	643023007		643023007	Nut, Hex, 1/2-13	12
11		643023007		Nut, Hex, 1/2-13	16
12	621012271	621012271	621012271	Screw, Set, Socket, 1/2-13 by 1	4
13	757160011	757160026	757160011	Pin, Hinge	2
14	600134000	600134000	600134000	Fitting, Grease, Straight	6
15	657356334	657356334	657356334	Handle Grip	2
16	757280017	757280027	757280010	Counterweight and Rod Assembly	2
17	621012266	621012266	621012266	Screw, Set, Cup Point, 1/2-13 by 1/2	4

ReL No.	Model 1018	Model 1016	Model 816	Part Name	Qty.
18	257020007	257020001	257020004	Beam	1

19	757080015	757080056	757080015	Bushing, Slide Pin	2
20	656164302	600164307	656164302	Ring Retaining, Slide Pin Bushing	2
21	457080076	457080009	457080076	Bushing, Eccentric	2
22	757030041	757030041	757030016	Radius Bar	1
23		613012131		Screw, Cap, Flathead, 5/16-18 by 3/4	21
23	613012131		613012131	Screw, Cap, Flathead, 5/16-18 by 3/4	17
24	257090008	257090002	257090006	Bed Assembly	1
25	757130036	757130036	757130036	Stop Rod, Apron	1
26	600083604	600083604	600083604	Pin, Clevis	1
27	600073549	600073549	600073549	Pin, Cotter, 3/32 by I -inch	1
28	757160038	757160038	757160038	Stud, Apron Stop	1
29	757260072	757260072	757260072	Collar, Apron Stop	1
30	621012125	621012125	621012125	Screw, Apron Stop Collar, 5/16-18 by 5/16	1
31	666023007	666023007	666023007	Nut, Apron Stop Stud	1
32	600134006	600134006	600134006	Fitting, Grease, 45 Degree	2
33	657164324	657164322	657164324	Ring, Retaining	2
34	757080018	757080052	757080018	Bushing, Lower Toggle Pin	2
35	757160096	757160089	757160096	Pin, Lower Toggle	2
36	671023010	671023012	671023010	Toggle Nut, lower	2
37	657033154	657033144	657033154	Washer, Spring See Note At Bottom Of Page	
38	645023010	645023012	645023010	Toggle Nut, Upper	2
39	757860007	757860050	757860007	Toggle Assembly, Right Hand	1
40	757860008	757860051	757860008	Toggle Assembly, Left Hand	1
41	757080009	757080053	757080009	Bushing, Toggle	2
42	757030003	757030059	757030003	Clamping Lever, Right Hand	1
43	757030004	757030060	757030004	Clamping Lever, Left Hand	1
44	657356334	657356334	657356334	Handle, Grip	2
45	657245118	657245119	657245118	Bearing, Thrust	2
46		678033113		Washer, Flat, I -I /8-inch	2
47	679033112	679033113	679033112	Washer, Split Lock	2
48	657000390	657000391	657000390	Collar, Clamping	2
49	757730005	757730001	757730005	Slide Plate, Right Hand	1
50	757730006	757730002	757730006	Slide Plate, Left Hand	1
51	611012410	611012410	611012410	Screw, Clamping	2
52	678033110	678033110	678033110	Washer, Clamping Screw	2
53	657000280	657000280	657000280	Adjusting Screw Assembly	2
54	617012266	617012266	617012266	Screw, Set, Socket Head, 1/2-13 by 1/2	2

#816 – 1018 only require 1 spring washer on the top and a part # 678033110 Flat washer on the bottom

